



# **iCE40 UltraPlus Family Data Sheet**

## **Data Sheet**

FPGA-DS-02008-2.2

July 2023

## Disclaimers

Lattice makes no warranty, representation, or guarantee regarding the accuracy of information contained in this document or the suitability of its products for any particular purpose. All information herein is provided AS IS and with all faults, and all risk associated with such information is entirely with Buyer. Buyer shall not rely on any data and performance specifications or parameters provided herein. Products sold by Lattice have been subject to limited testing and it is the Buyer's responsibility to independently determine the suitability of any products and to test and verify the same. No Lattice products should be used in conjunction with mission- or safety-critical or any other application in which the failure of Lattice's product could create a situation where personal injury, death, severe property or environmental damage may occur. The information provided in this document is proprietary to Lattice Semiconductor, and Lattice reserves the right to make any changes to the information in this document or to any products at any time without notice.

## Contents

Acronyms in This Document .....	7
1. General Description .....	8
1.1. Features .....	8
2. Product Family .....	9
2.1. Overview .....	9
3. Architecture .....	11
3.1. Architecture Overview .....	11
3.1.1. PLB Blocks .....	12
3.1.2. Routing .....	13
3.1.3. Clock/Control Distribution Network .....	13
3.1.4. sysCLOCK Phase Locked Loops (PLLs) .....	14
3.1.5. sysMEM Embedded Block RAM Memory .....	15
3.1.6. sysMEM Single Port RAM Memory (SPRAM) .....	17
3.1.7. sysDSP .....	18
3.1.8. sysI/O Buffer Banks .....	23
3.1.9. sysI/O Buffer .....	26
3.1.10. On-Chip Oscillator .....	26
3.1.11. User I <sup>2</sup> C IP .....	27
3.1.12. User SPI IP .....	27
3.1.13. RGB High Current Drive I/O Pins .....	27
3.1.14. RGB PWM IP .....	27
3.1.15. Non-Volatile Configuration Memory .....	28
3.2. iCE40 UltraPlus Programming and Configuration .....	28
3.2.1. Device Programming .....	28
3.2.2. Device Configuration .....	28
3.2.3. Power Saving Options .....	28
4. DC and Switching Characteristics .....	29
4.1. Absolute Maximum Ratings .....	29
4.2. Recommended Operating Conditions .....	29
4.3. Power Supply Ramp Rates .....	30
4.4. Power-On Reset .....	30
4.5. Power-up Supply Sequence .....	30
4.6. External Reset .....	30
4.7. Power-On-Reset Voltage Levels .....	31
4.8. ESD Performance .....	31
4.9. DC Electrical Characteristics .....	32
4.10. Supply Current .....	32
4.11. User I <sup>2</sup> C Specifications .....	33
4.12. I <sup>2</sup> C 50 ns Delay .....	33
4.13. I <sup>2</sup> C 50 ns Filter .....	33
4.14. User SPI Specifications .....	33
4.15. Internal Oscillators (HFOSC, LFOSC) .....	34
4.16. sysI/O Recommended Operating Conditions .....	34
4.17. sysI/O Single-Ended DC Electrical Characteristics .....	34
4.18. Differential Comparator Electrical Characteristics .....	34
4.19. Typical Building Block Function Performance .....	35
4.19.1. Pin-to-Pin Performance (LVCMOS25) .....	35

- 4.19.2. Register-to-Register Performance ..... 35
- 4.20. sysDSP Timing ..... 35
- 4.21. SPRAM Timing ..... 35
- 4.22. Derating Logic Timing ..... 36
- 4.23. Maximum sys/O Buffer Performance ..... 36
- 4.24. iCE40 UltraPlus Family Timing Adders ..... 36
- 4.25. iCE40 UltraPlus External Switching Characteristics ..... 37
- 4.26. sysCLOCK PLL Timing ..... 37
- 4.27. SPI Master or NVCM Configuration Time ..... 38
- 4.28. sysCONFIG Port Timing Specifications ..... 38
- 4.29. RGB LED Drive ..... 39
- 4.30. Switching Test Conditions ..... 39
- 5. Pinout Information ..... 40
  - 5.1. Signal Descriptions ..... 40
    - 5.1.1. Power Supply Pins ..... 40
    - 5.1.2. Configuration Pins ..... 40
    - 5.1.3. Configuration SPI Pins ..... 40
    - 5.1.4. Global Pins ..... 41
    - 5.1.5. General I/O, LED Pins ..... 41
  - 5.2. Pin Information Summary ..... 42
  - 5.3. iCE40UP Part Number Description ..... 43
    - 5.3.1. Tape and Reel Quantity ..... 43
  - 5.4. Ordering Part Numbers ..... 43
    - 5.4.1. Industrial ..... 43
- Supplemental Information ..... 44
- Technical Support Assistance ..... 45
- Revision History ..... 46

## Figures

Figure 3.1. iCE40UP5K Device, Top View .....	11
Figure 3.2. PLB Block Diagram .....	12
Figure 3.3. PLL Diagram .....	14
Figure 3.4. sysMEM Memory Primitives .....	16
Figure 3.5. SPRAM Primitive .....	17
Figure 3.6. sysDSP Functional Block Diagram (16-bit x 16-bit Multiply-Accumulate) .....	19
Figure 3.7. sysDSP 8-bit x 8-bit Multiplier .....	22
Figure 3.8. DSP 16-bit x 16-bit Multiplier .....	23
Figure 3.9. I/O Bank and Programmable I/O Cell .....	24
Figure 3.10. iCE I/O Register Block Diagram .....	25
Figure 4.1. Power Up Sequence with SPE_VCCIO1 and VPP_2V5 Not Connected Together .....	31
Figure 4.2. Power Up Sequence with All Supplies Connected Together to 1.8 V .....	31
Figure 4.3. Output Test Load, LVCMOS Standards .....	39

## Tables

Table 2.1. iCE40 UltraPlus Family Selection Guide .....	9
Table 3.1. Logic Cell Signal Descriptions .....	13
Table 3.2. Global Buffer (GBUF) Connections to Programmable Logic Blocks.....	13
Table 3.3. PLL Signal Descriptions.....	15
Table 3.4. sysMEM Block Configurations.....	15
Table 3.5. EBR Signal Descriptions .....	16
Table 3.6. SPRAM Signal Descriptions .....	18
Table 3.7. Output Block Port Description .....	19
Table 3.8. PIO Signal List .....	25
Table 3.9. Supported Input Standards .....	26
Table 3.10. Supported Output Standards .....	26
Table 3.11. iCE40 UltraPlus Power Saving Features Description .....	28
Table 4.1. Absolute Maximum Ratings .....	29
Table 4.2. Recommended Operating Conditions .....	29
Table 4.3. Power Supply Ramp Rates .....	30
Table 4.4. Power-On-Reset Voltage Levels .....	31
Table 4.5. DC Electrical Characteristics.....	32
Table 4.6. Supply Current .....	32
Table 4.7. User I <sup>2</sup> C Specifications.....	33
Table 4.8. I <sup>2</sup> C 50 ns Delay.....	33
Table 4.9. I <sup>2</sup> C 50 ns Filter .....	33
Table 4.10. User SPI Specifications .....	33
Table 4.11. Internal Oscillators (HFOSC, LFOSC) .....	34
Table 4.12. sysI/O Recommended Operating Conditions.....	34
Table 4.13. sysI/O Single-Ended DC Electrical Characteristics .....	34
Table 4.14. Differential Comparator Electrical Characteristics.....	34
Table 4.15. Pin-to-Pin Performance (LVCMOS25).....	35
Table 4.16. Register-to-Register Performance.....	35
Table 4.17. sysDSP Timing .....	35
Table 4.18. Single Port RAM Timing.....	35
Table 4.19. Maximum sysI/O Buffer Performance .....	36
Table 4.20. iCE40 UltraPlus Family Timing Adders .....	36
Table 4.21. iCE40 UltraPlus External Switching Characteristics.....	37
Table 4.22. sysCLOCK PLL Timing.....	37
Table 4.23. SPI Master or NVCM Configuration Time <sup>1, 2</sup> .....	38
Table 4.24. sysCONFIG Port Timing Specifications .....	38
Table 4.25. RGB LED.....	39
Table 4.26. Test Fixture Required Components, Non-Terminated Interfaces.....	39

## Acronyms in This Document

A list of acronyms used in this document.

Acronym	Definition
DFF	D-style Flip-Flop
DSP	Digital Signal Processor
EBR	Embedded Block RAM
HFOSC	High Frequency Oscillator
I <sup>2</sup> C	Inter-Integrated Circuit
LFOSC	Low Frequency Oscillator
LUT	Look Up Table
LVC MOS	Low-Voltage Complementary Metal Oxide Semiconductor
NVCM	Non Volatile Configuration Memory
PCLK	Primary Clock
PFU	Programmable Functional Unit
PIC	Programmable I/O Cells
PLB	Programmable Logic Blocks
PLL	Phase Locked Loops
SoC	System on a Chip
SPI	Serial Peripheral Interface
SPR	Single Port RAM
WLCSP	Wafer Level Chip Scale Packaging

# 1. General Description

iCE40 UltraPlus™ family from Lattice Semiconductor is an ultra-low power FPGA and sensor manager designed for ultra-low power mobile applications, such as smartphones, tablets and hand-held devices. iCE40 UltraPlus is compatible with Lattice iCE40 Ultra family devices, containing all the functions the iCE40 Ultra family has except the high current IR LED driver. In addition, the iCE40 UltraPlus features an additional 1 Mb SRAM, additional DSP blocks, with additional LUTs, all which can be used to support an always-on Voice Recognition function in the mobile devices, without the need to keep the higher power consuming voice codec on all the time.

The iCE40 UltraPlus family includes integrated SPI and I<sup>2</sup>C blocks to interface with virtually all mobile sensors and application processors. In addition, the iCE40 UltraPlus family also features two I/O pins that can support the interface to I3C devices. There are two on-chip oscillators, a 10 kHz one and a 48 MHz one, the LFOSC (10 kHz) is ideal for low power function in always-on applications, while HFOSC (48 MHz) can be used for awaken activities.

The iCE40 UltraPlus family also features the DSP functional block to off-load Application Processor to pre-process information sent from the mobile device, such as voice data. The RGB PWM IP, with the three 24 mA constant current RGB outputs on the iCE40 UltraPlus provides all the necessary logic to directly drive the service LED, without the need of external MOSFET or buffer.

The iCE40 UltraPlus family of devices are targeting for mobile applications to perform all the functions in iCE40 Ultra devices, such as Service LED, GPIO Expander, SDIO Level Shift, and other custom functions. In addition, the iCE40 UltraPlus family devices are also targeting for Voice Recognition application.

The iCE40 UltraPlus family features two device densities, 2800 to 5280 Look Up Tables (LUTs) of logic with programmable I/Os that can be used as either SPI/I<sup>2</sup>C interface ports or general purpose I/Os. Two of the iCE40 UltraPlus I/Os can be used to interface to higher performance I3C. It also has up to 120 kb of Block RAMs, plus 1024 kb of Single Port SRAMs to work with user logic.

## 1.1. Features

- Flexible Logic Architecture
  - Two devices with 2800 to 5280 LUTs
  - Offered in WLCS and QFN packages
- Ultra-low Power Devices
  - Advanced 40 nm low power process
  - As low as 100  $\mu$ A standby current typical
- Embedded Memory
  - Up to 1024 kb Single Port SRAM
  - Up to 120 kb sysMEM™ Embedded Block RAM
- Two Hardened I<sup>2</sup>C Interfaces
  - Two I/O pins to support I3C interface
- Two Hardened SPI Interfaces
- Two On-Chip Oscillators
  - Low Frequency Oscillator – 10 kHz
  - High Frequency Oscillator – 48 MHz
- 24 mA Current Drive RGB LED Outputs
  - Three drive outputs in each device
  - User selectable sink current up to 24 mA
- On-chip DSP
  - Signed and unsigned 8-bit or 16-bit functions
  - Functions include Multiplier, Accumulator, and Multiply-Accumulate (MAC)
- Flexible On-Chip Clocking
  - Eight low skew global signal resource, six can be directly driven from external pins
  - One PLL with dynamic interface per device
- Flexible Device Configuration
  - SRAM is configured through:
    - Standard SPI Interface
    - Internal Nonvolatile Configuration Memory (NVCM)
- Ultra-Small Form Factor
  - As small as 2.11 mm × 2.54 mm
- Applications
  - Always-On Voice Recognition Application
  - Smartphones
  - Tablets and Consumer Handheld Devices
  - Handheld Commercial and Industrial Devices
  - Multi Sensor Management Applications
  - Sensor Pre-processing and Sensor Fusion
  - Always-On Sensor Applications
  - USB 3.1 Type C Cable Detect / Power Delivery Applications

## 2. Product Family

Table 2.1 lists device information and packages of the iCE40 UltraPlus family.

**Table 2.1. iCE40 UltraPlus Family Selection Guide**

Part Number	iCE40UP3K	iCE40UP5K
<b>Logic Cells (LUT + Flip-Flop)</b>	<b>2800</b>	<b>5280</b>
EBR Memory Blocks	20	30
EBR Memory Bits (kbits)	80	120
SPRAM Memory Blocks	4	4
SPRAM Memory Bits (kbits)	1024	1024
NVCM	Yes	Yes
PLL	1	1
DSP Blocks (MULT16 with 32-bit Accumulator)	4	8
Hardened I <sup>2</sup> C, SPI	2, 2	2, 2
HF Oscillator (48 MHz)	1	1
LF Oscillator (10 kHz)	1	1
24 mA LED Sink	3	3
PWM IP Block	Yes	Yes
<b>Packages, Ball Pitch, Dimension</b>	<b>Total User I/O Count</b>	
30-ball WLCSP, 0.4 mm, 2.11 mm × 2.54 mm	21	21
48-ball QFN, 0.5 mm, 7.0 mm × 7.0 mm	—	39

### 2.1. Overview

The iCE40 UltraPlus family of ultra-low power FPGAs has three devices with densities ranging from 2800 to 5280 Look-Up Tables (LUTs) fabricated in a 40 nm Low Power CMOS process. In addition to LUT-based, low-cost programmable logic, these devices also feature Embedded Block RAM (EBR), Single Port RAM (SPRAM), on-chip Oscillators (LFOSC, HFOSC), two hardened I<sup>2</sup>C Controllers, two hardened SPI Controllers, PWM IP, three 24 mA RGB LED open-drain drivers, I3C interface pins, and DSP blocks. These features allow the devices to be used in low-cost, high-volume consumer and mobile applications.

The iCE40 UltraPlus FPGAs are available in very small form factor packages, as small as 2.11 mm × 2.54 mm. The small form factor allows the device to easily fit into a lot of mobile applications, where space can be limited. Table 2.1 lists the LUT densities, package and I/O pin count.

The iCE40 UltraPlus devices offer I/O features such as pull-up resistors. Pull-up features are controllable on a “per pin” basis. In addition, the iCE40 UltraPlus devices offer two I/Os with dynamic control on the pull-up resistors to support I3C interface.

The RGB PWM IP in the iCE40 UltraPlus devices provides controls for driving the 24 mA LED Sink driver, including color controls, LED ON/OFF time, and breathe rate.

The iCE40 UltraPlus devices also provide flexible, reliable and secure configuration from on-chip NVCM. These devices can also configure themselves from external SPI Flash, or be configured by an external master such as a CPU. Lattice provides a variety of design tools that allow complex designs to be efficiently implemented using the iCE40 UltraPlus family of devices. Popular logic synthesis tools provide synthesis library support for iCE40 UltraPlus. Lattice design tools use the synthesis tool output along with the user-specified preferences and constraints to place and route the design in the iCE40 UltraPlus device. These tools extract the timing from the routing and back-annotate it into the design for timing verification.

Lattice provides many pre-engineered IP (Intellectual Property) modules, including a number of reference designs, licensed free of charge, optimized for the iCE40 UltraPlus FPGA family. Lattice also can provide fully verified bitstream for some of the widely used target functions in mobile device applications, such as ultra-low power sensor management, gesture recognition, IR remote, barcode emulator functions. Users can use these functions as offered by Lattice, or they can use the design to create their own unique required functions. For more information regarding Lattice reference designs or fully-verified bitstreams, contact your local Lattice representative.

## 3. Architecture

### 3.1. Architecture Overview

The iCE40 UltraPlus family architecture contains an array of Programmable Logic Blocks (PLB), two Oscillator Generators, two user configurable I<sup>2</sup>C controllers, two user configurable SPI controllers, blocks of sysMEM™ Embedded Block RAM (EBR) and Single Port RAM (SPRAM) surrounded by Programmable I/O (PIO). Figure 3.1 shows the block diagram of the iCE40UP5K device.

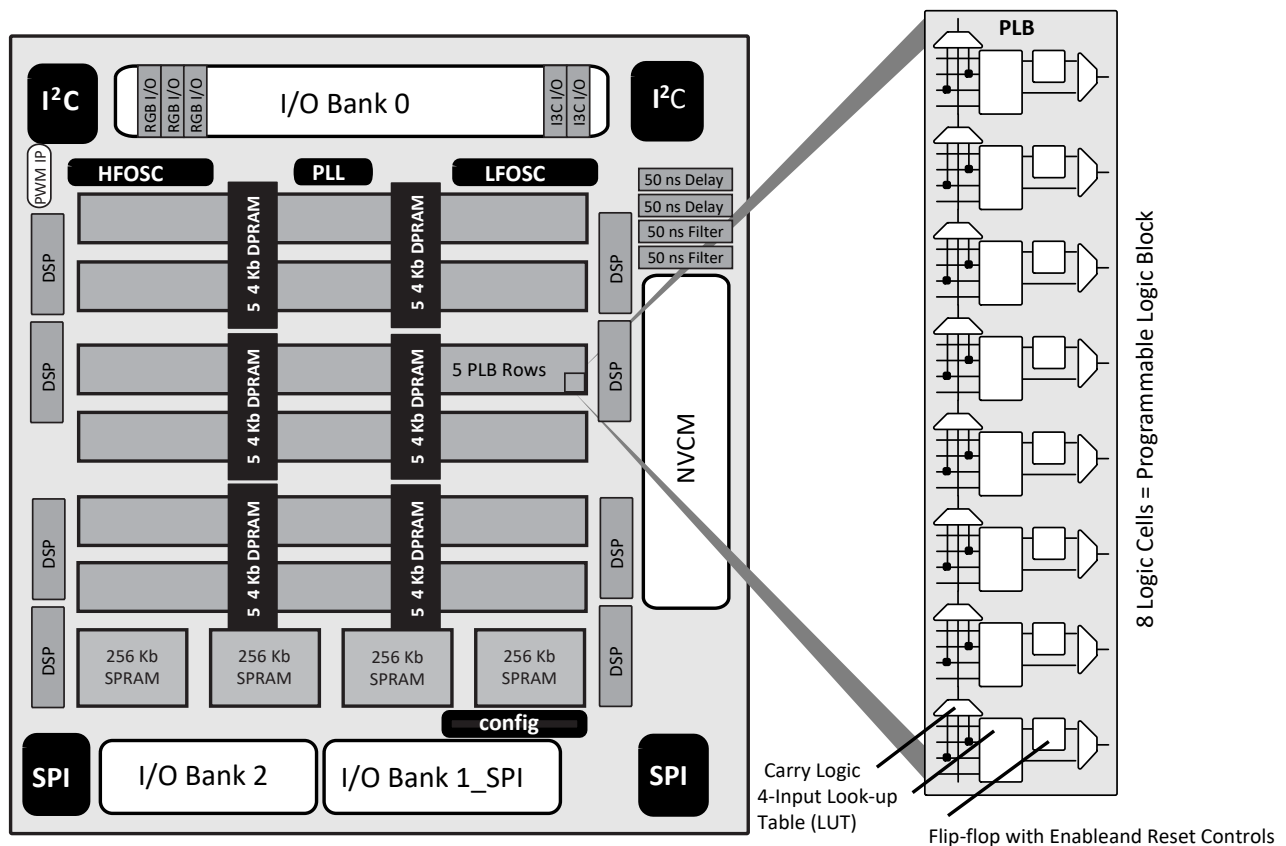

**Figure 3.1. iCE40UP5K Device, Top View**

The Programmable Logic Blocks (PLB) and sysMEM EBR blocks, are arranged in a two-dimensional grid with rows and columns. Each column has either PLB or EBR blocks. The PIO cells are located at the top and bottom of the device, arranged in banks. The PLB contains the building blocks for logic, arithmetic, and register functions. The PIOs utilize a flexible I/O buffer referred to as a sysI/O buffer that supports operation with a variety of interface standards. The blocks are connected with many vertical and horizontal routing channel resources. The place and route software tool automatically allocates these routing resources.

In the iCE40 UltraPlus family, there are three sysI/O banks, one on top and two at the bottom. User can connect some V<sub>CCIO</sub>s together, if all the I/Os are using the same voltage standard. See the [Power-up Supply Sequence](#) section. The sysMEM EBRs are large 4 kb, dedicated fast memory blocks. These blocks can be configured as RAM, ROM or FIFO with user logic using PLBs.

In addition to the EBR, the iCE40 UltraPlus devices also feature four 256 kb SPRAM blocks that can be cascaded to create up to 1 Mb block. It is useful for temporary storage of large quantities of information.

Every device in the family has two user SPI ports, one of them (on the right side) also supports programming and configuration of the device. The iCE40 UltraPlus also includes two user I<sup>2</sup>C ports, two oscillators, and high current RGB LED sink.

### 3.1.1. PLB Blocks

The core of the iCE40 UltraPlus device consists of Programmable Logic Blocks (PLB) which can be programmed to perform logic and arithmetic functions. Each PLB consists of eight interconnected Logic Cells (LC), as shown in Figure 3.2. Each LC contains one LUT and one register.

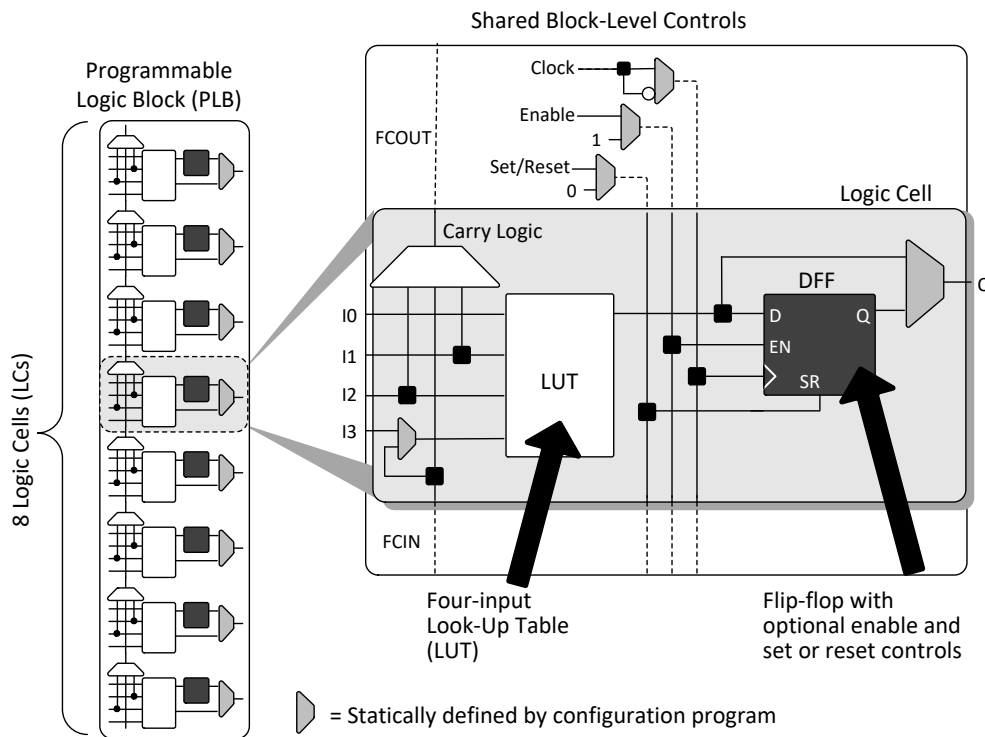

Figure 3.2. PLB Block Diagram

#### Logic Cells

Each Logic Cell includes three primary logic elements shown in Figure 3.2.

- A four-input Look-Up Table (LUT) builds any combinational logic function, of any complexity, requiring up to four inputs. Similarly, the LUT element behaves as a 16x1 Read-Only Memory (ROM). Combine and cascade multiple LUTs to create wider logic functions.
- A 'D'-style Flip-Flop (DFF), with an optional clock-enable and reset control input, builds sequential logic functions. Each DFF also connects to a global reset signal that is automatically and immediately asserted following device configuration.
- Carry Logic boosts the logic efficiency and performance of arithmetic functions, including adders, subtracters, comparators, binary counters and some wide, cascaded logic functions.

Table 3.1 lists the logic cell signals.

**Table 3.1. Logic Cell Signal Descriptions**

Function	Type	Signal Name	Description
Input	Data signal	I0, I1, I2, I3	Inputs to LUT
Input	Control signal	Enable	Clock enable shared by all LCs in the PLB.
Input	Control signal	Set/Reset <sup>1</sup>	Asynchronous or synchronous local set/reset shared by all LCs in the PLB.
Input	Control signal	Clock	Clock one of the eight Global Buffers, or from the general-purpose interconnects fabric shared by all LCs in the PLB.
Input	Inter-PLB signal	FCIN	Fast carry in
Output	Data signals	O	LUT or registered output
Output	Inter-PFU signal	FCOUT	Fast carry out

**Note:**

1. If Set/Reset is not used, then the flip-flop is never set/reset, except when cleared immediately after configuration.

### 3.1.2. Routing

There are many resources provided in the iCE40 UltraPlus devices to route signals individually with related control signals. The routing resources consist of switching circuitry, buffers and metal interconnect (routing) segments.

The inter-PLB connections are made with three different types of routing resources: Adjacent (spans two PLBs), x4 (spans five PLBs) and x12 (spans thirteen PLBs). The Adjacent, x4 and x12 connections provide fast and efficient connections in the diagonal, horizontal and vertical directions.

The design tool takes the output of the synthesis tool and places and routes the design.

### 3.1.3. Clock/Control Distribution Network

Each iCE40 UltraPlus device has six global inputs, two pins on the top bank and four pins on the bottom bank.

These global inputs can be used as high fanout nets, clock, reset or enable signals. The dedicated global pins are identified as Gxx and each drives one of the eight global buffers. The global buffers are identified as GBUF[7:0]. These six inputs may be used as general purpose I/O if they are not used to drive the clock nets.

Table 3.2 lists the connections between a specific global buffer and the inputs on a PLB. All global buffers optionally connect to the PLB CLK input. Any four of the eight global buffers can drive logic inputs to a PLB. Even-numbered global buffers optionally drive the Set/Reset input to a PLB. Similarly, odd-numbered buffers optionally drive the PLB clock-enable input. GBUF[7:6, 3:0] can connect directly to G[7:6, 3:0] pins respectively. GBUF4 and GBUF5 can connect to the two on-chip Oscillator Generators (GBUF4 connects to LFOSC, GBUF5 connects to HFOSC).

**Table 3.2. Global Buffer (GBUF) Connections to Programmable Logic Blocks**

Global Buffer	LUT Inputs	Clock	Reset	Clock Enable
GBUF0	Yes, any 4 of 8 GBUF Inputs	✓	✓	—
GBUF1		✓	—	✓
GBUF2		✓	✓	—
GBUF3		✓	—	✓
GBUF4		✓	✓	—
GBUF5		✓	—	✓
GBUF6		✓	✓	—
GBUF7		✓	—	✓

The maximum frequency for the global buffers are listed in Table 4.21.

### Global Hi-Z Control

The global high-impedance control signal, GHIZ, connects to all I/O pins on the iCE40 UltraPlus device. This GHIZ signal is automatically asserted throughout the configuration process, forcing all user I/O pins into their high-impedance state.

### Global Reset Control

The global reset control signal connects to all PLB and PIO flip-flops on the iCE40 UltraPlus device. The global reset signal is automatically asserted throughout the configuration process, forcing all flip-flops to their defined wake-up state. For PLB flip-flops, the wake-up state is always reset, regardless of the PLB flip-flop primitive used in the application.

### 3.1.4. sysCLOCK Phase Locked Loops (PLLs)

The sysCLOCK PLLs provide the ability to synthesize clock frequencies. The iCE40 UltraPlus devices have one sysCLOCK PLL. REFERENCECLK is the reference frequency input to the PLL and its source can come from an external I/O pin, the internal Oscillator Generators from internal routing. EXTFEEDBACK is the feedback signal to the PLL which can come from internal routing or an external I/O pin. The feedback divider is used to multiply the reference frequency and thus synthesize a higher frequency clock output.

The PLLOUT output has an output divider, thus allowing the PLL to generate different frequencies for each output. The output divider can have a value from 1 to 64 (in increments of 2X). The PLLOUT outputs can all be used to drive the iCE40 UltraPlus global clock network directly or general purpose routing resources can be used.

The LOCK signal is asserted when the PLL determines it has achieved lock and de-asserted if a loss of lock is detected. A block diagram of the PLL is shown in Figure 3.3.

The timing of the device registers can be optimized by programming a phase shift into the PLLOUT output clock which advances or delays the output clock with reference to the REFERENCECLK clock. This phase shift can be either programmed during configuration or can be adjusted dynamically. In dynamic mode, the PLL may lose lock after a phase adjustment on the output used as the feedback source and not relock until the tLOCK parameter has been satisfied.

For more details, refer to [iCE40 sysCLOCK PLL Design and Usage Guide \(FPGA-TN-02052\)](#).

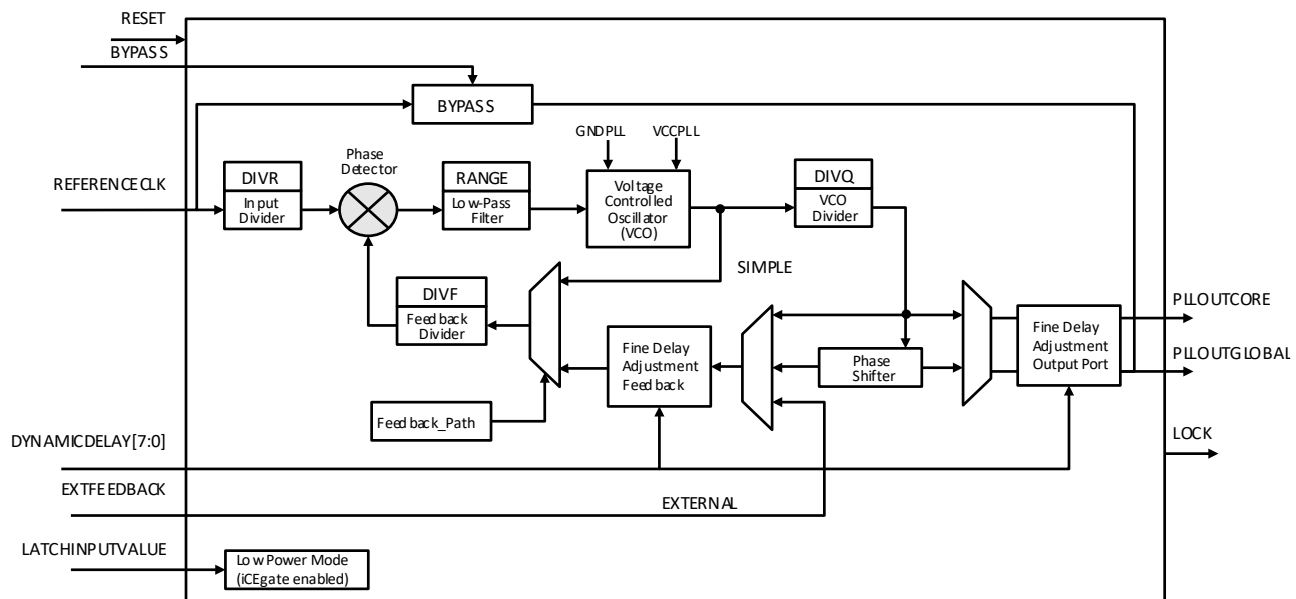

Figure 3.3. PLL Diagram

Table 3.3 provides signal descriptions of the PLL block.

**Table 3.3. PLL Signal Descriptions**

Signal Name	Direction	Description
REFERENCECLK	Input	Input reference clock.
BYPASS	Input	The BYPASS control selects which clock signal connects to the PLLOUT output. 0 – PLL generated signal 1 – REFERENCECLK
EXTFEEDBACK	Input	External feedback input to PLL. Enabled when the FEEDBACK_PATH attribute is set to EXTERNAL.
DYNAMICDELAY[7:0]	Input	Fine delay adjustment control inputs. Enabled when DELAY_ADJUSTMENT_MODE is set to DYNAMIC.
LATCHINPUTVALUE	Input	When enabled, puts the PLL into low-power mode; PLL output is held static at the last input clock value. Set ENABLE ICEGATE_PORTA and PORTB to '1' to enable.
PLLOUTGLOBAL	Output	Output from the Phase-Locked Loop (PLL). Drives a global clock network on the FPGA. The port has optimal connections to global clock buffers GBUF4 and GBUF5.
PLLOUTCORE	Output	Output clock generated by the PLL, drives regular FPGA routing. The frequency generated on this output is the same as the frequency of the clock signal generated on the PLLOUTGLOBAL port.
LOCK	Output	When High, indicates that the PLL output is phase aligned or locked to the input reference clock.
RESET	Input	Active low reset.
SCLK	Input	Input, Serial Clock used for re-programming PLL settings.
SDI	Input	Input, Serial Data used for re-programming PLL settings.

### 3.1.5. sysMEM Embedded Block RAM Memory

Larger iCE40 UltraPlus device includes multiple high-speed synchronous sysMEM Embedded Block RAMs (EBRs), each 4 kbit in size. This memory can be used for a wide variety of purposes including data buffering and FIFO.

#### sysMEM Memory Block

The sysMEM block can implement single port, pseudo dual port, or FIFO memories with programmable logic resources. Each block can be used in a variety of depths and widths as listed in [Table 3.4](#).

**Table 3.4. sysMEM Block Configurations**

Block RAM Configuration	Block RAM Configuration and Size	WADDR Port Size (Bits)	WDATA Port Size (Bits)	RADDR Port Size (Bits)	RDATA Port Size (Bits)	MASK Port Size (Bits)
SB_RAM256x16 SB_RAM256x16NR SB_RAM256x16NW SB_RAM256x16NRNW	256x16 (4 k)	8 [7:0]	16 [15:0]	8 [7:0]	16 [15:0]	16 [15:0]
SB_RAM512x8 SB_RAM512x8NR SB_RAM512x8NW SB_RAM512x8NRNW	512x8 (4 k)	9 [8:0]	8 [7:0]	9 [8:0]	8 [7:0]	No Mask Port
SB_RAM1024x4 SB_RAM1024x4NR SB_RAM1024x4NW SB_RAM1024x4NRNW	1024x4 (4 k)	10 [9:0]	4 [3:0]	10 [9:0]	4 [3:0]	No Mask Port
SB_RAM2048x2 SB_RAM2048x2NR SB_RAM2048x2NW SB_RAM2048x2NRNW	2048x2 (4 k)	11 [10:0]	2 [1:0]	11 [10:0]	2 [1:0]	No Mask Port

**Note:** For iCE40 UltraPlus, the primitive name without “Nx” uses rising-edge Read and Write clocks. “NR” uses rising-edge Write clock and falling-edge Read clock. “NW” uses falling-edge Write clock and rising-edge Read clock. “NRNW” uses failing-edge clocks on both Read and Write.

### RAM Initialization and ROM Operation

If desired, the contents of the RAM can be pre-loaded during device configuration.

By preloading the RAM block during the chip configuration cycle and disabling the write controls, the sysMEM block can also be utilized as a ROM.

### Memory Cascading

Larger and deeper blocks of RAM can be created using multiple EBR sysMEM Blocks.

### RAM4k Block

Figure 3.4 shows the 256x16 memory configurations and their input/output names. In all the sysMEM RAM modes, the input data and addresses for the ports are registered at the input of the memory array.

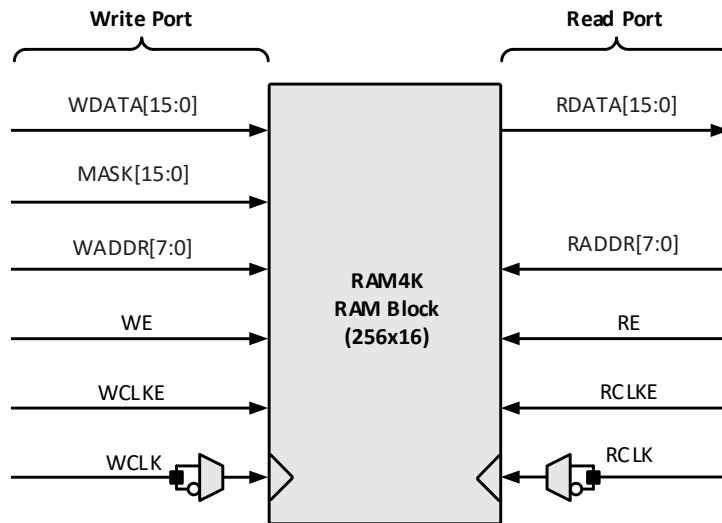

Figure 3.4. sysMEM Memory Primitives

Table 3.5 lists the EBR signals.

Table 3.5. EBR Signal Descriptions

Signal Name	Direction	Description
WDATA[15:0]	Input	Write Data Input
MASK[15:0]	Input	Masks write operations for individual data bit-lines. 0 – Write bit 1 – Do not write bit
WADDR[7:0]	Input	Write Address Input. Selects one of 256 possible RAM locations.
WE	Input	Write Enable Input
WCLKE	Input	Write Clock Enable Input
WCLK	Input	Write Clock Input. Default rising-edge, but with falling-edge option.
RDATA[15:0]	Output	Read Data Output
RADDR[7:0]	Input	Read Address Input. Selects one of 256 possible RAM locations.
RE	Input	Read Enable Input
RCLKE	Input	Read Clock Enable Input
RCLK	Input	Read Clock Input. Default rising-edge, but with falling-edge option.

For further information on the sysMEM EBR block, refer to [Memory Usage Guide for iCE40 Devices \(FPGA-TN-02002\)](#).

### 3.1.6. sysMEM Single Port RAM Memory (SPRAM)

The SPRAM block is implemented to be accessed only as a single port. Each block of SPRAM is designed to be 16K x 16 (256 kbits) in size. See [Figure 3.5](#).

#### SPRAM Data Width

The SPRAM is designed with fixed 16-bit data width. However, the block contains nibble mask control on the write input that allows the user logic to operate the SPRAM as x4 or x8 with this control on the write side. It also allows the user logic to select which nibble/byte is in the read side.

#### SPRAM Initialization and ROM Operation

There is no pre-load into the SPRAM during device configuration. Therefore, the SPRAM is not initialized after configuration.

#### SPRAM Cascading

Deeper SPRAM can be created using multiple SPRAM blocks, up to four blocks (64K x 16).

#### SPRAM Power Modes

There are three power modes in the SPRAM that the users can select during normal operation. This reduces the SPRAM block power when it is not needed, allowing lower power consumption in an always-on application. These modes are:

- **Standby Mode:** SPRAM stops all activity, and SPRAM freezes in its current state. Memory contents are retained, memory outputs are retained, and all register contents are retained.
- **Sleep Mode:** SPRAM block is shut down on all peripheral circuit, except the memory core. Memory contents are retained, memory outputs and register contents are clear and become unknown.
- **Power Off Mode:** Power source to the SPRAM is disconnected. This is the lowest power state. Memory contents are lost. Memory outputs are unknown.

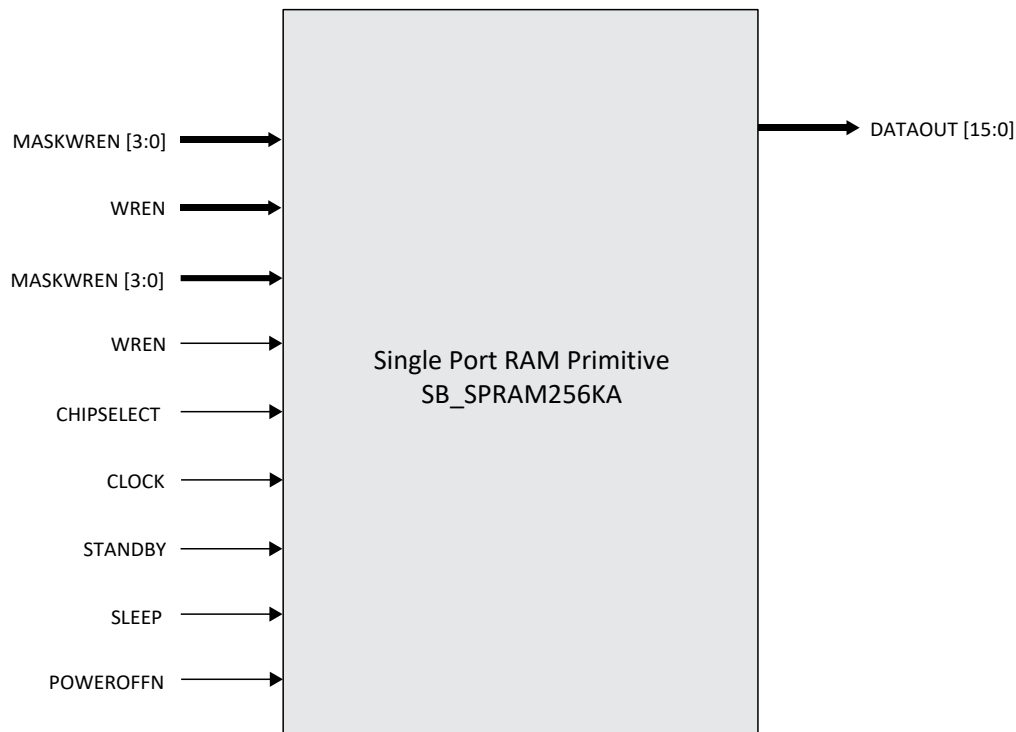

**Figure 3.5. SPRAM Primitive**

**Table 3.6. SPRAM Signal Descriptions**

Signal Name	Direction	Description
ADDRESS[13:0]	Input	Address Input
DATAIN[15:0]	Input	Write Data Input
MASKWREN[3:0]	Input	Nibble WE Control
WREN	Input	Write Enable
CHIPSELECT	Input	Enable SPRAM
CLOCK	Input	Clock Input
STANDY	Input	Standby Mode
SLEEP	Input	Sleep Mode
POWEROFF	Input	Switch Off Power Source to SPRAM
DATAOUT[15:0]	Output	Output Data

For further information on sysMEM SPRAM block, refer to [iCE40 SPRAM Usage Guide \(FPGA-TN-02022\)](#).

### 3.1.7. sysDSP

The iCE40 UltraPlus family provides an efficient sysDSP architecture that is very suitable for low-cost Digital Signal Processing (DSP) functions for mobile applications. Typical functions used in these applications are Multiply, Accumulate, and Multiply-Accumulate. The block can also be used for simple Add and Subtract functions.

#### iCE40 UltraPlus sysDSP Architecture Features

The iCE40 UltraPlus sysDSP supports many functions that include the following:

- Single 16-bit x 16-bit Multiplier, or two independent 8-bit x 8-bit Multipliers
- Optional independent pipeline control on Input Register, Output Register, and Intermediate Reg faster clock performance
- Single 32-bit Accumulator, or two independent 16-bit Accumulators
- Single 32-bit, or two independent 16-bit Adder/Subtractor functions, registered or asynchronous
- Cascadable to create wider Accumulator blocks

[Figure 3.6](#) shows the block diagram of the sysDSP block. The block consists of the Multiplier section with a bypassable Output register, Input Register, and Intermediate register between Multiplier and AC timing to achieve the highest performance.

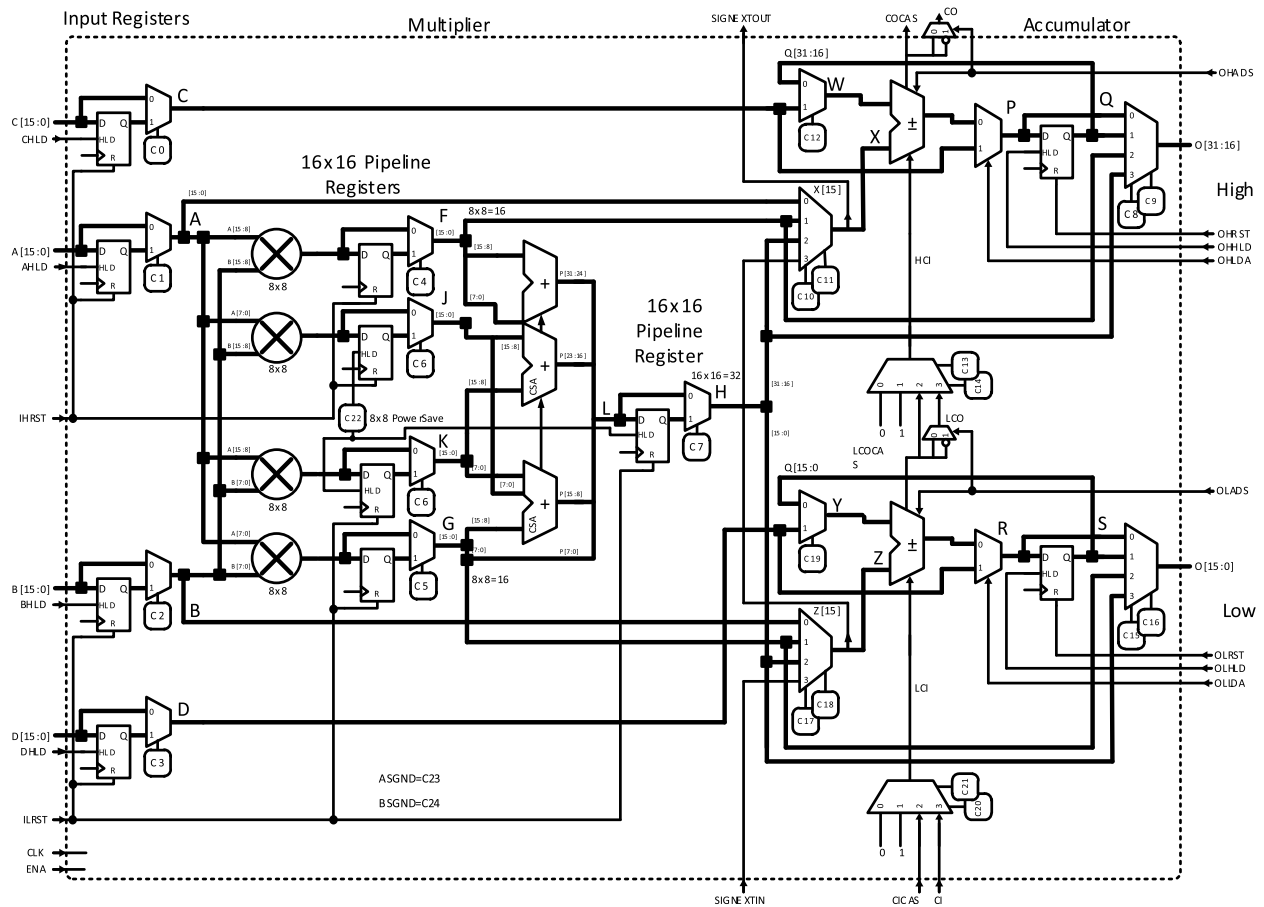

Figure 3.6. sysDSP Functional Block Diagram (16-bit x 16-bit Multiply-Accumulate)

Table 3.7. Output Block Port Description

Signal	Primitive Port Name	Width	Input/Output	Function	Default
CLK	CLK	1	Input	Clock Input. Applies to all clocked elements in the sysDSP block.	—
ENA	CE	1	Input	Clock Enable Input. Applies to all clocked elements in the sysDSP block. 0 – Not enabled 1 – Enabled	0 – Enabled
A[15:0]	A[15:0]	16	Input	Input to the A Register. Feeds the Multiplier or is a direct input to the Adder Accumulator.	16'b0
B[15:0]	B[15:0]	16	Input	Input to the B Register. Feeds the Multiplier or is a direct input to the Adder Accumulator.	16'b0
C[15:0]	C[15:0]	16	Input	Input to the C Register. It is a direct input to the Adder Accumulator.	16'b0
D[15:0]	D[15:0]	16	Input	Input to the D Register. It is a direct input to the Adder Accumulator.	16'b0
AHLD	AHOLD	1	Input	A Register Hold. 0 – Update 1 – Hold	0 – Update
BHLD	BHOLD	1	Input	B Register Hold. 0 – Update 1 – Hold	0 – Update

Signal	Primitive Port Name	Width	Input/Output	Function	Default
CHLD	CHOLD	1	Input	C Register Hold. 0 – Update 1 – Hold	0 – Update
DHLD	DHOLD	1	Input	D Register Hold. 0 – Update 1 – Hold	0 – Update
IHRST	IRSTTOP	1	Input	Reset input to A and C input registers, and the pipeline registers in the upper half of the Multiplier Section. 0 – No reset 1 – Reset	0 – No reset
ILRST	IRSTBOT	1	Input	Reset input to B and D input registers, and the pipeline registers in the lower half of the Multiplier Section. It also resets the Multiplier result pipeline register. 0 – No reset 1 – Reset	0 – No reset
O[31:0]	O[31:0]	32	Output	Output of the sysDSP block. This output can be: <ul style="list-style-type: none"> <li>O[31:0] – 32-bit result of 16x16 Multiplier or MAC</li> <li>O[31:16] – 16-bit result of 8x8 upper half Multiplier or MAC</li> <li>O[15:0] – 16-bit result of 8x8 lower half Multiplier or MAC</li> </ul>	—
OHHLD	OHOLDTOP	1	Input	High-order (upper half) Accumulator Register Hold. 0 – Update 1 – Hold	0 – Update
OHRST	ORSTTOP	1	Input	Reset input to high-order (upper half) bits of the Accumulator Register. 0 – No reset 1 – Reset	0 – No reset
OHLDA	OLOADTOP	1	Input	High-order (upper half) Accumulator Register Accumulate/Load control. 0 – Accumulate, register is loaded with Adder/Subtractor results 1 – Load, register is loaded with Input C or C Register	0 – Accumulate
OHADS	ADDSUBTOP	1	Input	High-order (upper half) Accumulator Add or Subtract select. 0 – Add 1 – Subtract	0 – Add
OLHLD	OHOLDBOT	1	Input	Low-order (lower half) Accumulator Register Hold. 0 – Update 1 – Hold	0 – Update
OLRST	ORSTBOT	1	Input	Reset input to Low-order (lower half) bits of the Accumulator Register. 0 – No reset 1 – Reset	0 – No reset

Signal	Primitive Port Name	Width	Input/Output	Function	Default
OLLDA	OLOADBOT	1	Input	Low-order (lower half) Accumulator Register Accumulate/Load control. 0 – Accumulate, register is loaded with Adder/Subtractor results 1 – Load, register is loaded with Input C or C Register	0 – Accumulate
OLADS	ADDSUBBOT	1	Input	Low-order (lower half) Accumulator Add or Subtract select. 0 – Add 1 – Subtract	0 – Add
CICAS	ACCUMCI	1	Input	Cascade Carry/Borrow input from previous sysDSP block.	—
CI	CI	1	Input	Carry/Borrow input from lower logic tile.	—
COCAS	ACCUMCO	1	Output	Cascade Carry/Borrow output to next sysDSP block.	—
CO	CO	1	Output	Carry/Borrow output to higher logic tile.	—
SIGNEXTIN	SIGNEXTIN	1	Input	Sign extension input from previous sysDSP block.	—
SIGNEXTOUT	SIGNEXTOUT	1	Output	Sign extension output to next sysDSP block.	—

The iCE40 UltraPlus sysDSP can support the following functions:

- 8-bit x 8-bit Multiplier
- 16-bit x 16-bit Multiplier
- 16-bit Adder/Subtractor
- 32-bit Adder/Subtractor
- 16-bit Accumulator
- 32-bit Accumulator
- 8-bit x 8-bit Multiply-Accumulate
- 16-bit x 16-bit Multiply-Accumulate

Figure 3.7 shows the path for an 8-bit x 8-bit Multiplier using the upper half of sysDSP block.

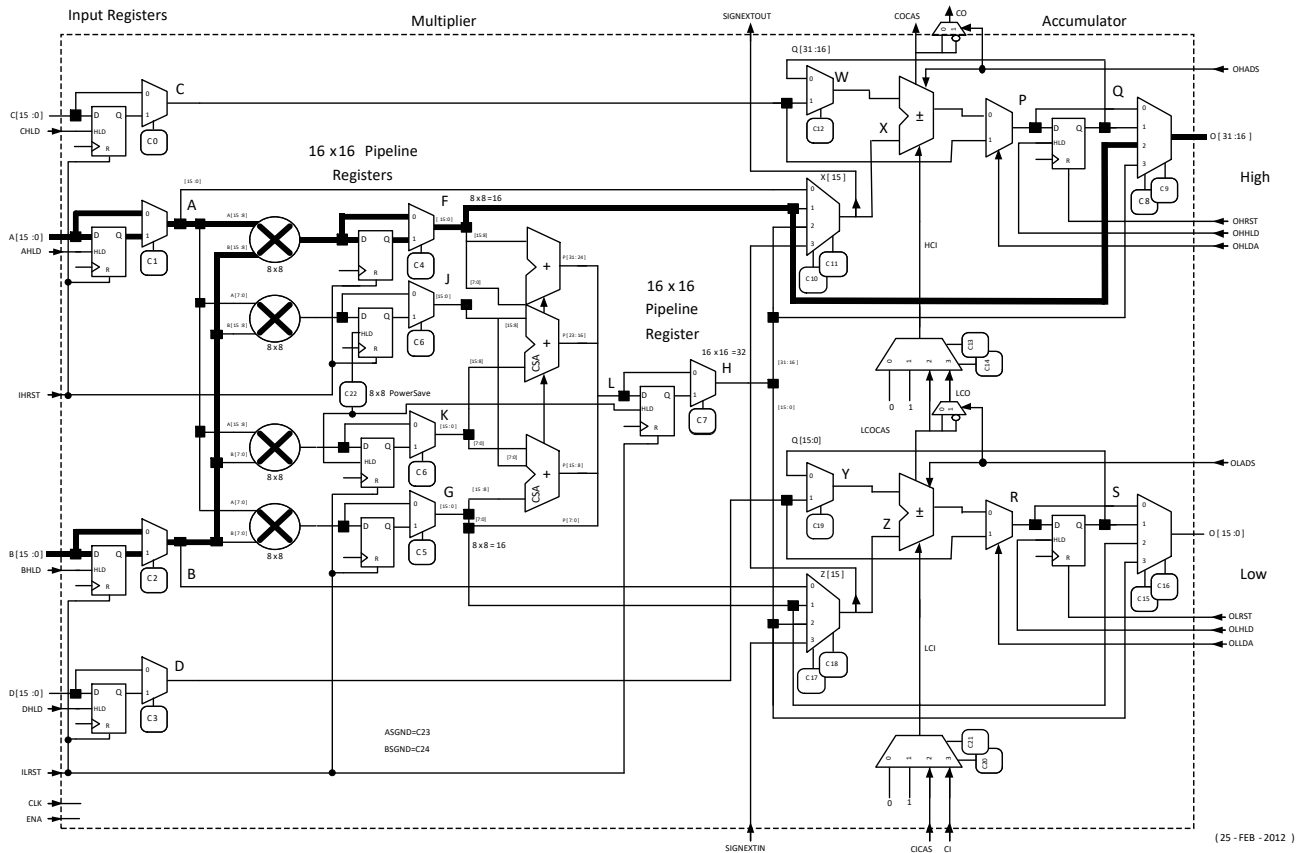

Figure 3.7. sysDSP 8-bit x 8-bit Multiplier

Figure 3.8 shows the path for an 16-bit x 16-bit Multiplier using the upper half of sysDSP block.

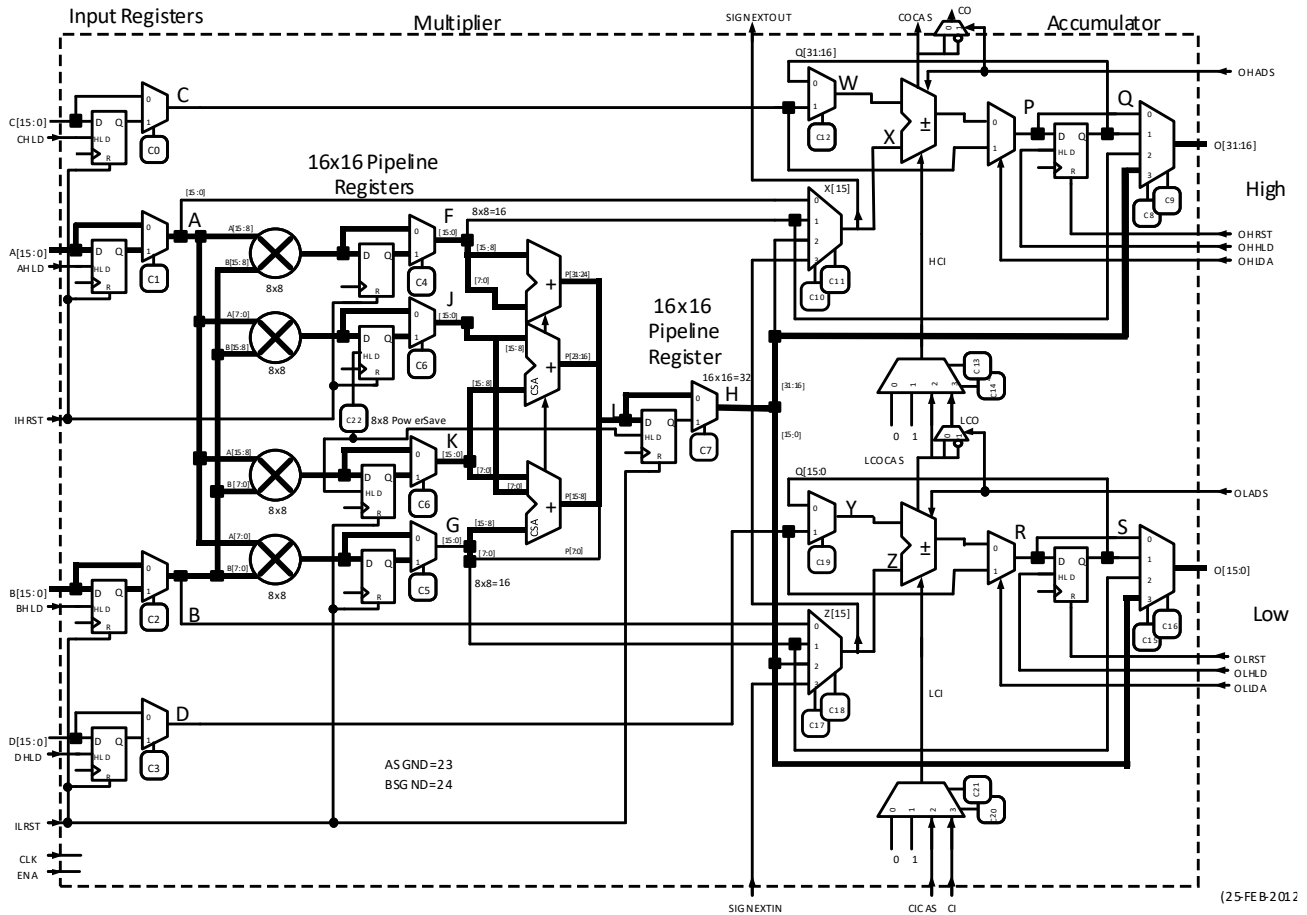

Figure 3.8. DSP 16-bit x 16-bit Multiplier

### 3.1.8. sys/O Buffer Banks

iCE40 UltraPlus devices have up to three I/O banks with independent  $V_{CCIO}$  rails. The configuration SPI interface signals are powered by  $SPI\_V_{CCIO1}$ . Refer to the [Pin Information Summary](#) table.

#### Programmable I/O (PIO)

The programmable logic associated with an I/O is called a PIO. The individual PIOs are connected to their respective sys/O buffers and pads. The PIOs are placed on the top and bottom of the devices.

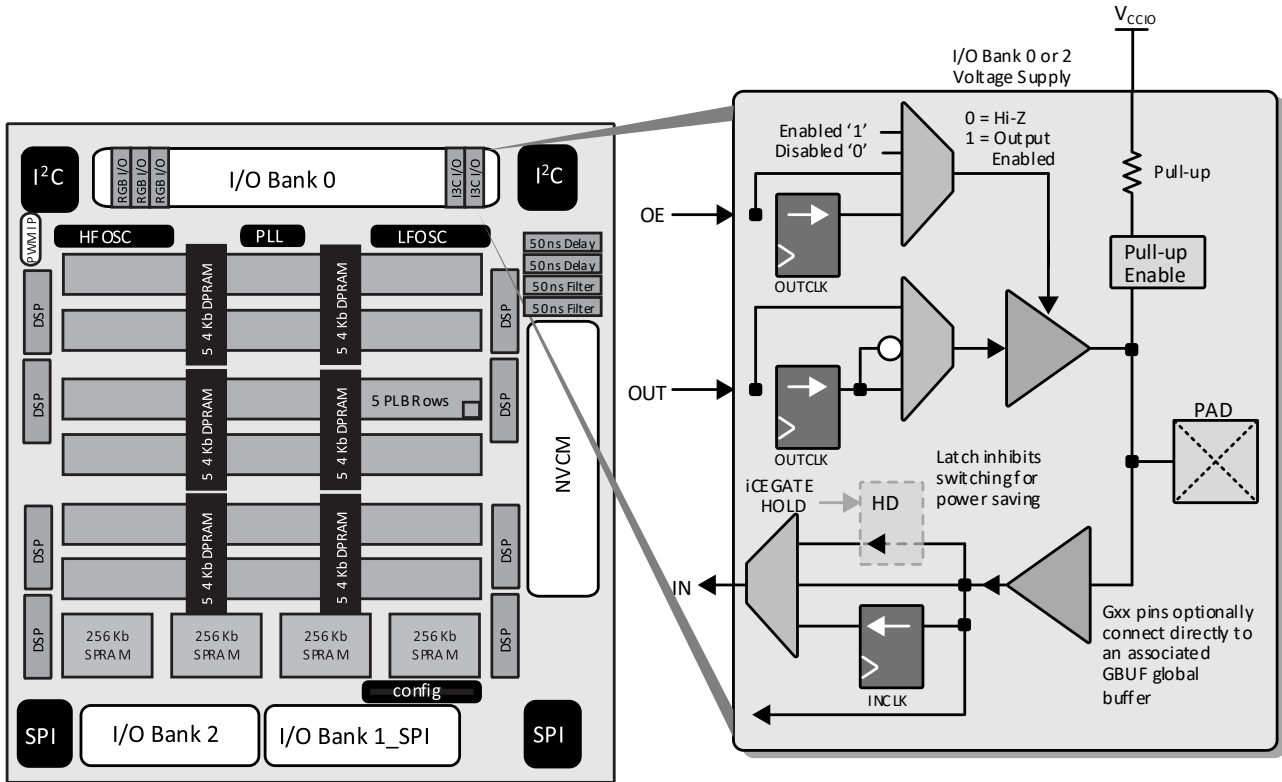

**Figure 3.9. I/O Bank and Programmable I/O Cell**

The PIO contains three blocks: an input register block, output register block iCEGate™ and tri-state register block. To save power, the optional iCEGate™ latch can selectively freeze the state of individual, non-registered inputs within an I/O bank. Note that the freeze signal is common to the bank. These blocks can operate in a variety of modes along with the necessary clock and selection logic.

**Input Register Block**

The input register blocks for the PIOs on all edges contain registers that can be used to condition high-speed interface signals before they are passed to the device core.

**Output Register Block**

The output register block can optionally register signals from the core of the device before they are passed to the sysI/O buffers.

Figure 3.10 shows the input/output register block for the PIOs.

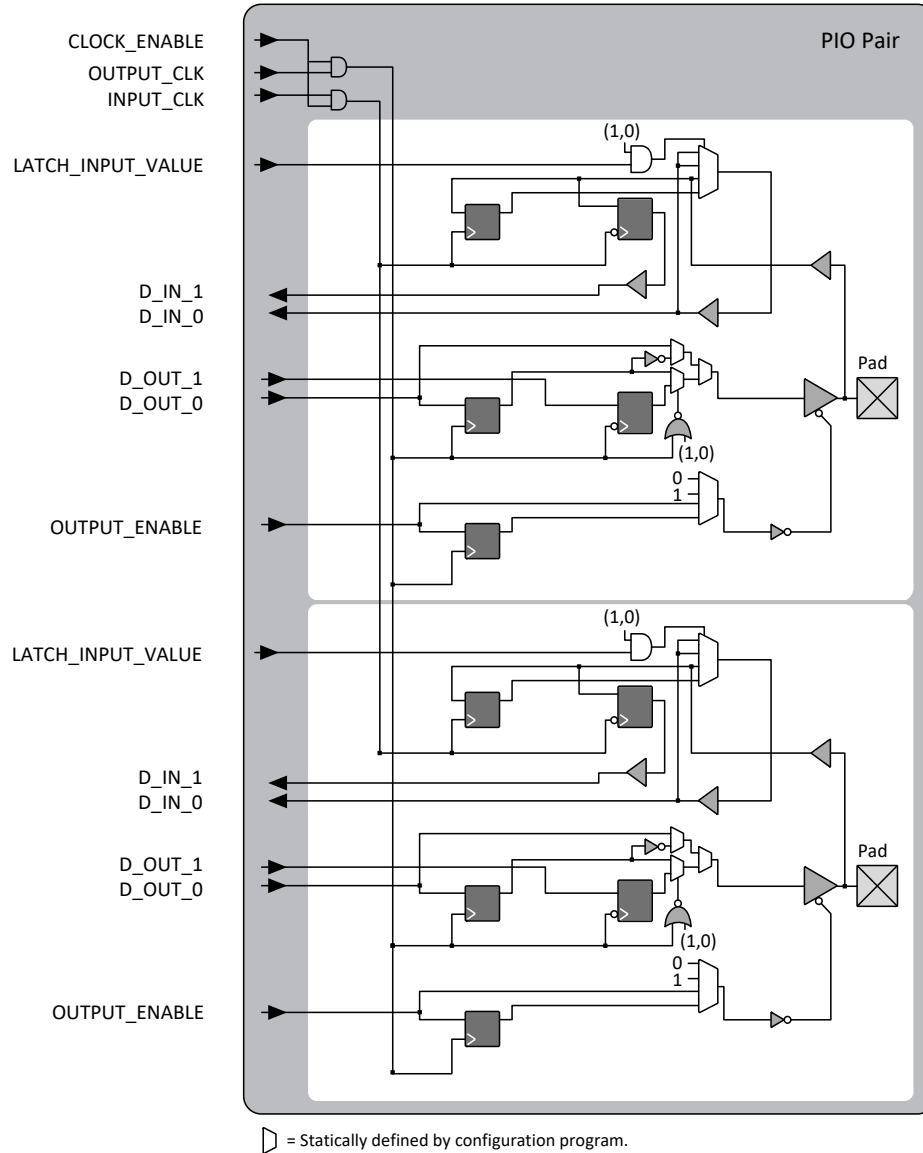

**Figure 3.10. iCE I/O Register Block Diagram**

**Table 3.8. PIO Signal List**

Pin Name	I/O Type	Description
OUTPUT_CLK	Input	Output Register Clock
CLOCK_ENABLE	Input	Clock Enable
INPUT_CLK	Input	Input Register Clock
OUTPUT_ENABLE	Input	Output Enable
D_OUT_0/1	Input	Data from the Core
D_IN_0/1	Output	Data to the Core
LATCH_INPUT_VALUE	Input	Latches/Holds the Input Value

### 3.1.9. sysI/O Buffer

Each I/O is associated with a flexible buffer referred to as a sysI/O buffer. These buffers are arranged around the periphery of the device in groups referred to as banks. The sysI/O buffers allow users to implement a wide variety of standards that are found in today's systems with LVCMOS interfaces.

#### Typical I/O Behavior During Power-up

The internal power-on-reset (POR) signal is deactivated when  $V_{CC}$ ,  $SPI\_V_{CCIO1}$  and  $V_{PP\_2V5}$  reach the level defined in Table 4.4. After the POR signal is deactivated, the FPGA core logic becomes active. You must ensure that all  $V_{CCIO}$  banks are active with valid input logic levels to properly control the output logic states of all the I/O banks that are critical to the application. The default configuration of the I/O pins in a device prior to configuration is tri-stated with a weak pull-up to  $V_{CCIO}$ . The I/O pins maintain the pre-configuration state until  $V_{CC}$ ,  $SPI\_V_{CCIO1}$  and  $V_{PP\_2V5}$  reach the defined levels. The I/Os take on the software user-configured settings only after POR signal is deactivated and the device performs a proper download/configuration. Unused I/Os are automatically blocked and the pull-up termination is disabled.

#### Supported Standards

The iCE40 UltraPlus sysI/O buffer supports both single-ended input/output standards, and used as differential comparators. The buffer supports the LVCMOS 1.8 V, 2.5 V, and 3.3 V standards. The buffer has individually configurable options for bus maintenance (weak pull-up or none).

Table 3.9 and Table 3.10 show the I/O standards (together with their supply and reference voltages) supported by the iCE40 UltraPlus devices.

#### Differential Comparators

The iCE40 UltraPlus devices provide differential comparator on pairs of I/O pins. These comparators are useful in some mobile applications. Refer to the [Pin Information Summary](#) section for the number of paired I/O available in each bank to implement differential comparators. Refer to the device pinout file from the Lattice website for exact pin locations.

**Table 3.9. Supported Input Standards**

I/O Standard	$V_{CCIO}$ (Typical)		
	3.3 V	2.5 V	1.8 V
<b>Single-Ended Interfaces</b>			
LVCMS33	Yes	—	—
LVCMS25	—	Yes	—
LVCMS18	—	—	Yes

**Table 3.10. Supported Output Standards**

I/O Standard	$V_{CCIO}$ (Typical)
<b>Single-Ended Interfaces</b>	
LVCMS33	3.3 V
LVCMS25	2.5 V
LVCMS18	1.8 V

### 3.1.10. On-Chip Oscillator

The iCE40 UltraPlus devices feature two different frequency Oscillator. One is tailored for low-power operation that runs at low frequency (LFOSC). Both Oscillators are controlled with internally generated current.

The LFOSC runs at nominal frequency of 10 kHz. The high frequency oscillator (HFOSC) runs at a nominal frequency of 48 MHz, divisible to 24 MHz, 12 MHz, or 6 MHz by user option. The LFOSC can be used to perform all always-on functions, with the lowest power possible. The HFOSC can be enabled when the always-on functions detect a condition that would need to wake up the system to perform higher frequency functions.

### 3.1.11. User I<sup>2</sup>C IP

The iCE40 UltraPlus devices have two I<sup>2</sup>C IP cores. Either of the two cores can be configured either as an I<sup>2</sup>C master or as an I<sup>2</sup>C slave. The pins for the I<sup>2</sup>C interface are not pre-assigned. User can use any General Purpose I/O pins.

In each of the two cores, there are options to delay either the input or the output, or both, by 50 ns nominal, using dedicated on-chip delay elements. This provides an easier interface with any external I<sup>2</sup>C components.

When the IP core is configured as master, it will be able to control other devices on the I<sup>2</sup>C bus through the pre-assigned pin interface. When the core is configured as the slave, the device is able to provide I/O expansion to an I<sup>2</sup>C Master. The I<sup>2</sup>C cores support the following functionality:

- Master and Slave operation
- 7-bit and 10-bit addressing
- Multi-master arbitration support
- Clock stretching
- Up to 400 kHz data transfer speed
- General Call support
- Optionally delaying input or output data, or both
- Optional filter on SCL input

For further information on the User I<sup>2</sup>C, refer to [iCE40 SPI/I2C Hardened IP Usage Guide \(FPGA-TN-02010\)](#).

### 3.1.12. User SPI IP

The iCE40 UltraPlus devices have two SPI IP cores. The pins for the SPI interface are not pre-assigned. User can use any General Purpose I/O pins. Both SPI IP cores can be configured as a SPI master or as a slave. When the SPI IP core is configured as a master, it controls the other SPI enabled devices connected to the SPI Bus. When SPI IP core is configured as a slave, the device is able to interface to an external SPI master.

The SPI IP core supports the following functions:

- Configurable Master and Slave modes
- Full-Duplex data transfer
- Mode fault error flag with CPU interrupt capability
- Double-buffered data register
- Serial clock with programmable polarity and phase
- LSB First or MSB First Data Transfer

For further information on the User SPI, refer to [iCE40 SPI/I2C Hardened IP Usage Guide \(FPGA-TN-02010\)](#).

### 3.1.13. RGB High Current Drive I/O Pins

The iCE40 UltraPlus family devices offer multiple high current LED drive outputs in each device in the family to allow the iCE40 UltraPlus product to drive LED signals directly on mobile applications.

There are three outputs on each device that can sink up to 24 mA current. These outputs are open-drain outputs, and provides sinking current to an LED connecting to the positive supply. These three outputs are designed to drive the RGB LEDs, such as the service LED found in a lot of mobile devices. This RGB drive current is user programmable from 4 mA to 24 mA, in increments of 4 mA. This output functions as General Purpose I/O with open-drain when the high current drive is not needed.

### 3.1.14. RGB PWM IP

To provide an easier usage of the RGB high current drivers to drive RGB LED, a Pulse-Width Modulator IP can be used in the user design. This PWM IP provides the flexibility for user to dynamically change the modulation width of each of the RGB LED driver, which changes the color. Also, the user can dynamically change the settings on the ON-time duration, OFF-time duration, and ability to turn the LED lights on and off gradually with user set breath-on and breath-off time.

For additional information on the PWM IP, refer to [iCE40 LED Driver Usage Guide \(FPGA-TN-02021\)](#).

### 3.1.15. Non-Volatile Configuration Memory

All iCE40 UltraPlus devices provide a Non-Volatile Configuration Memory (NVCM) block which can be used to configure the device.

For more information on the NVCM, refer to [iCE40 Programming and Configuration \(FPGA-TN-02001\)](#).

## 3.2. iCE40 UltraPlus Programming and Configuration

This section describes the programming and configuration of the iCE40 UltraPlus family.

### 3.2.1. Device Programming

The NVCM memory can be programmed through the SPI port. The SPI port is located in Bank 1, using SPI\_V<sub>CCIO1</sub> power supply.

### 3.2.2. Device Configuration

There are various ways to configure the Configuration RAM (CRAM), using SPI port, including:

- From a SPI Flash (Master SPI mode)
- System microprocessor to drive a Serial Slave SPI port (SSPI mode)

For more details on configuring the iCE40 UltraPlus, refer to [iCE40 Programming and Configuration \(FPGA-TN-02001\)](#).

### 3.2.3. Power Saving Options

The iCE40 UltraPlus devices feature iCEGate and PLL low power mode to allow users to meet the static and dynamic power requirements of their applications. [Table 3.11](#) describes the function of these features.

**Table 3.11. iCE40 UltraPlus Power Saving Features Description**

Device Subsystem	Feature Description
PLL	When LATCHINPUTVALUE is enabled, puts the PLL into low-power mode; PLL output held static at last input clock value.
iCEGate	To save power, the optional iCEGate latch can selectively freeze the state of individual, non-registered inputs within an I/O bank. Registered inputs are effectively frozen by their associated clock or clock-enable control.

## 4. DC and Switching Characteristics

### 4.1. Absolute Maximum Ratings

**Table 4.1. Absolute Maximum Ratings**

Parameter	Min	Max	Unit
Supply Voltage $V_{CC}$	-0.5	1.42	V
Output Supply Voltage $V_{CCIO}$	-0.5	3.60	V
NVCM Supply Voltage $V_{PP\_2V5}$	-0.5	3.60	V
PLL Supply Voltage $V_{CCPLL}$	-0.5	1.42	V
I/O Tri-state Voltage Applied	-0.5	3.60	V
Dedicated Input Voltage Applied	-0.5	3.60	V
Storage Temperature (Ambient)	-65	150	°C
Junction Temperature ( $T_j$ )	-65	125	°C

**Notes:**

- Stress above those listed under the *Absolute Maximum Ratings* may cause permanent damage to the device. Functional operation of the device at these or any other conditions above those indicated in the operational sections of this specification is not implied.
- Compliance with the [Thermal Management](#) document is required.
- All voltages referenced to GND.

### 4.2. Recommended Operating Conditions

**Table 4.2. Recommended Operating Conditions**

Symbol	Parameter	Min	Max	Unit	
$V_{CC}^1$	Core Supply Voltage	1.14	1.26	V	
$V_{PP\_2V5}$	Slave SPI Configuration Master SPI Configuration Configuration from NVCM NVCM Programming	1.71 <sup>4</sup>	3.46	V	
		2.30	3.46	V	
		2.30	3.46	V	
		2.30	3.00	V	
$V_{CCIO}^{1, 2, 3}$	I/O Driver Supply Voltage	$V_{CCIO\_0}, SPI\_V_{CCIO1}, V_{CCIO\_2}$	1.71	3.46	V
$V_{CCPLL}$	PLL Supply Voltage	1.14	1.26	V	
$t_{JCOM}$	Junction Temperature Commercial Operation	0	85	°C	
$t_{JIND}$	Junction Temperature, Industrial Operation	-40	100	°C	
$t_{PROG}$	Junction Temperature NVCM Programming	10.00	30.00	°C	

**Notes:**

- Like power supplies must be tied together if they are at the same supply voltage and they meet the power up sequence requirement. See the [Power-up Supply Sequence](#) section.  $V_{CC}$  and  $V_{CCPLL}$  are recommended to be tied together to the same supply with an RC-based noise filter between them. Refer to [iCE40 Hardware Checklist \(FPGA-TN-02006\)](#).
- See recommended voltages by I/O standard in subsequent table.
- $V_{CCIO}$  pins of unused I/O banks should be connected to the  $V_{CC}$  power supply on boards.
- $V_{PP\_2V5}$  can, optionally, be connected to a 1.8 V (+/-5%) power supply in Slave SPI Configuration modes subject to the condition that none of the HFOSC/LFOSC and RGB LED driver features are used. Otherwise,  $V_{PP\_2V5}$  must be connected to a power supply with a minimum 2.30 V level.

### 4.3. Power Supply Ramp Rates

**Table 4.3. Power Supply Ramp Rates**

Symbol	Parameter	Min	Max	Unit
$t_{\text{RAMP}}$	Power supply ramp rates for all power supplies	0.6	10	V/ms

**Notes:**

- Assumes monotonic ramp rates.
- Power up sequence must be followed. See the [Power-up Supply Sequence](#) section below.

### 4.4. Power-On Reset

All iCE40 UltraPlus devices have on-chip Power-On-Reset (POR) circuitry to ensure proper initialization of the device. Only three supply rails are monitored by the POR circuitry as follows: (1) VCC, (2) SPI\_VCCIO1 and (3) VPP\_2V5. All other supply pins have no effect on the power-on reset feature of the device. Note that all supply voltage pins must be connected to power supplies for normal operation (including device configuration).

### 4.5. Power-up Supply Sequence

It is recommended to bring up the power supplies in the following order. Note that there is no specified timing delay between the power supplies, however, there is a requirement for each supply to reach a level of 0.5 V, or higher, before any subsequent power supplies in the sequence are applied.

- VCC** and **VCCPLL** should be the first two supplies to be applied. Note that these two supplies can be tied together subject to the recommendation to include an RC-based noise filter on the VCCPLL. Refer to [iCE40 Hardware Checklist \(FPGA-TN-02006\)](#).
- SPI\_VCCIO1** should be the next supply, and can be applied any time after the previous supplies (VCC and VCCPLL) have reached as level of 0.5 V or higher.
- VPP\_2V5** should be the next supply, and can be applied any time after previous supplies (VCC, VCCPLL and SPI\_VCCIO1) have reached a level of 0.5 V or higher.
- Other Supplies** (VCCIO0 and VCCIO2) do not affect device power-up functionality, and they can be applied any time after the initial power supplies (VCC and VCCPLL) have reached a level of 0.5 V or greater. There is no power down sequence required. However, when partial power supplies are powered down, it is required the above sequence to be followed when these supplies are re-powered up again.

**Note:** To check the  $V_{\text{SUPPLY(MIN)}}$  shown in [Figure 4.1](#), please refer to the minimum recommended operation conditions in the [Recommended Operating Conditions](#) section.

### 4.6. External Reset

When all power supplies have reached their minimum operating voltage defined in [Table 4.2](#), it is required to either keep CRESET\_B LOW, or toggle CRESET\_B from HIGH to LOW, for a duration of  $t_{\text{CRESET\_B}}$ , and release it to go HIGH, to start configuration download from either the internal NVCM or the external Flash memory. [Figure 4.1](#) shows Power-Up sequence when SPI\_VCCIO1 and VPP\_2V5 are not connected together, and the CRESET\_B signal triggers configuration download. [Figure 4.2](#) shows when SPI\_VCCIO1 and VPP\_2V5 are connected together. All power supplies should be powered up during configuration. Before and during configuration, the I/Os are held in tri-state. I/Os are released to user functionality once the device has finished configuration.

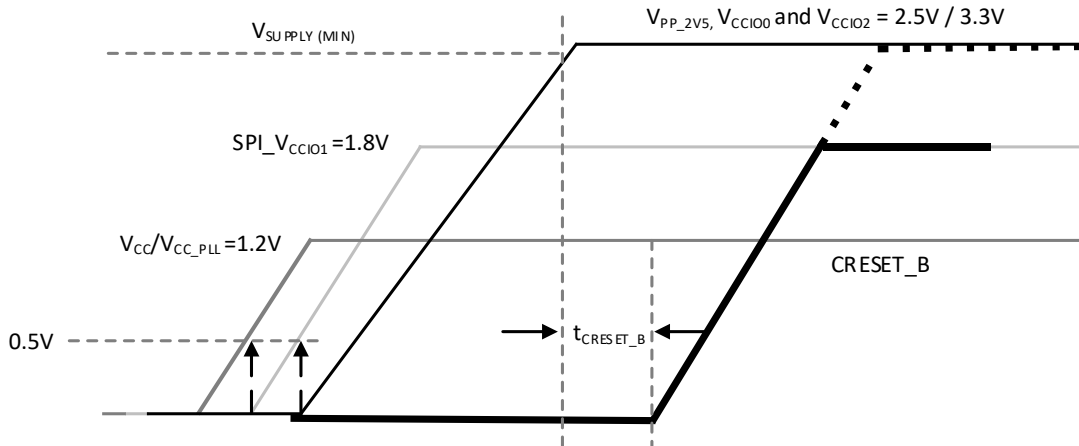

Figure 4.1. Power Up Sequence with SPE\_VCCIO1 and VPP\_2V5 Not Connected Together

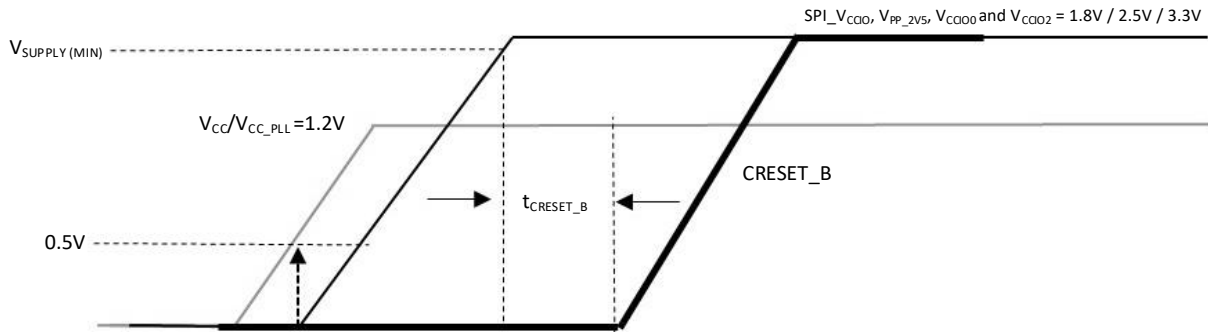

Figure 4.2. Power Up Sequence with All Supplies Connected Together to 1.8 V

## 4.7. Power-On-Reset Voltage Levels

Table 4.4. Power-On-Reset Voltage Levels

Symbol	Parameter		Min	Max	Unit
V <sub>PORUP</sub>	Power-On-Reset ramp up trip point (circuit monitoring V <sub>CC</sub> , SPI_VCCIO1, and V <sub>PP_2V5</sub> )	V <sub>CC</sub>	0.62	0.92	V
		SPI_VCCIO1	0.87	1.50	V
		V <sub>PP_2V5</sub>	0.90	1.53	V
V <sub>PORDN</sub>	Power-On-Reset ramp down trip point (circuit monitoring V <sub>CC</sub> , SPI_VCCIO1, and V <sub>PP_2V5</sub> )	V <sub>CC</sub>	—	0.79	V
		SPI_VCCIO1	—	1.50	V
		V <sub>PP_2V5</sub>	—	1.53	V

**Note:**

1. These POR trip points are only provided for guidance. Device operation is only characterized for power supply voltages specified under recommended operating conditions.

## 4.8. ESD Performance

Please contact Lattice Semiconductor for additional information.

## 4.9. DC Electrical Characteristics

Over recommended operating conditions.

**Table 4.5. DC Electrical Characteristics**

Symbol	Parameter	Condition	Min	Typ	Max	Unit
$I_{IL}, I_{IH}^{1, 3, 4}$	Input or I/O Leakage	$0\text{ V} < V_{IN} < V_{CCIO} + 0.2\text{ V}$	—	—	$\pm 10$	$\mu\text{A}$
$C_1$	I/O Capacitance, excluding LED Drivers <sup>2</sup>	$V_{CCIO} = 3.3\text{ V}, 2.5\text{ V}, 1.8\text{ V}$ $V_{CC} = \text{Typ}, V_{IO} = 0\text{ to } V_{CCIO} + 0.2\text{ V}$	—	6	—	pF
$C_2$	Global Input Buffer Capacitance <sup>2</sup>	$V_{CCIO} = 3.3\text{ V}, 2.5\text{ V}, 1.8\text{ V}$ $V_{CC} = \text{Typ}, V_{IO} = 0\text{ to } V_{CCIO} + 0.2\text{ V}$	—	6	—	pF
$C_3$	RGB Pin Capacitance <sup>2</sup>	$V_{CC} = \text{Typ}, V_{IO} = 0\text{ to } 3.5\text{ V}$	—	15	—	pF
$C_4$	IRLED Pin Capacitance <sup>2</sup>	$V_{CC} = \text{Typ}, V_{IO} = 0\text{ to } 3.5\text{ V}$	—	53	—	pF
$V_{HYST}$	Input Hysteresis	$V_{CCIO} = 1.8\text{ V}, 2.5\text{ V}, 3.3\text{ V}$	—	200	—	mV
$I_{PU}$	Internal PIO Pull-up Current	$V_{CCIO} = 1.8\text{ V}, 0 \leq V_{IN} \leq 0.65 * V_{CCIO}$	-3	—	-31	$\mu\text{A}$
		$V_{CCIO} = 2.5\text{ V}, 0 \leq V_{IN} \leq 0.65 * V_{CCIO}$	-8	—	-72	$\mu\text{A}$
		$V_{CCIO} = 3.3\text{ V}, 0 \leq V_{IN} \leq 0.65 * V_{CCIO}$	-11	—	-128	$\mu\text{A}$

**Notes:**

- Input or I/O leakage current is measured with the pin configured as an input or as an I/O with the output driver tri-stated. It is not measured with the output driver active. Internal pull-up resistors are disabled.
- $T_J$  25 °C,  $f = 1.0\text{ MHz}$ .
- Refer to  $V_{IL}$  and  $V_{IH}$  in [Table 4.13](#).
- Input pins are clamped to  $V_{CCIO}$  and GND by a diode. When input is higher than  $V_{CCIO}$  or lower than GND, the Input Leakage current is higher than the  $I_{IL}$  and  $I_{IH}$ .

## 4.10. Supply Current

**Table 4.6. Supply Current**

Symbol	Parameter	Typ $V_{CC} = 1.2\text{ V}$	Unit
$I_{CCSTDBY}$	Core Power Supply Static Current	75	$\mu\text{A}$
$I_{PP2V5STDBY}$	$V_{PP\_2V5}$ Power Supply Static Current	0.55	$\mu\text{A}$
$I_{SPI\_VCCIO1STDBY}$	SPI_ $V_{CCIO1}$ Power Supply Static Current	0.5	$\mu\text{A}$
$I_{CCIOSTDBY}$	$V_{CCIO}$ Power Supply Static Current	0.5	$\mu\text{A}$
$I_{CCPEAK}$	Core Power Supply Startup Peak Current	12	mA
$I_{PP\_2V5PEAK}$	$V_{PP\_2V5}$ Power Supply Startup Peak Current	2.5	mA
$I_{SPI\_VCCIO1PEAK}$	SPI_ $V_{CCIO1}$ Power Supply Startup Peak Current	9.0	mA
$I_{CCIOPEAK}$	$V_{CCIO}$ Power Supply Startup Peak Current	2.0	mA

**Notes:**

- Assumes blank pattern with the following characteristics: all outputs are tri-stated, all inputs are configured as LVCMOS and held at  $V_{CCIO}$  or GND, on-chip PLL is off. For more detail with your specific design, use the Power Calculator tool. Power specified with master SPI configuration mode. Other modes may be up to 25% higher.
- Frequency = 0 MHz.
- $T_J = 25\text{ °C}$ , power supplies at nominal voltage, on devices processed in nominal process conditions.
- Does not include pull-up.
- Startup Peak Currents are measured with decoupling capacitances of 0.1  $\mu\text{F}$ , 10 nF, and 1 nF to the power supply. Higher decoupling capacitance causes higher current.

## 4.11. User I<sup>2</sup>C Specifications

**Table 4.7. User I<sup>2</sup>C Specifications**

Symbol	Parameter	Spec (STD Mode)			Spec (FAST Mode)			Unit
		Min	Typ	Max	Min	Typ	Max	
f <sub>SCL</sub>	Maximum SCL Clock Frequency	—	—	100	—	—	400	kHz
t <sub>HI</sub>	SCL Clock HIGH Time	4	—	—	0.6	—	—	μs
t <sub>LO</sub>	SCL Clock LOW Time	4.7	—	—	1.3	—	—	μs
t <sub>SU,DAT</sub>	Setup Time (DATA)	250	—	—	100	—	—	ns
t <sub>HD,DAT</sub>	Hold Time (DATA)	0	—	—	0	—	—	ns
t <sub>SU,STA</sub>	Setup Time (START Condition)	4.7	—	—	0.6	—	—	μs
t <sub>HD,STA</sub>	Hold Time (START Condition)	4	—	—	0.6	—	—	μs
t <sub>SU,STO</sub>	Setup Time (STOP Condition)	4	—	—	0.6	—	—	μs
t <sub>BUF</sub>	Bus Free Time between STOP and START	4.7	—	—	1.3	—	—	μs
t <sub>CO,DAT</sub>	SCL LOW to DATAOUT Valid	—	—	3.4	—	—	0.9	μs

## 4.12. I<sup>2</sup>C 50 ns Delay

**Table 4.8. I<sup>2</sup>C 50 ns Delay**

Symbol	Parameter	Spec			Unit
		Min	Typ	Max	
T <sub>DELAY</sub>	Delay through 50 ns Delay Block	—	50	—	ns

## 4.13. I<sup>2</sup>C 50 ns Filter

**Table 4.9. I<sup>2</sup>C 50 ns Filter**

Symbol	Parameter	Spec			Unit
		Min	Typ	Max	
T <sub>FILTER-H</sub>	HIGH Pulse Filter through 50 ns Filter Block	—	50	—	ns
T <sub>FILTER-L</sub>	LOW Pulse Filter through 50 ns Filter Block	—	50	—	ns

## 4.14. User SPI Specifications

**Table 4.10. User SPI Specifications**

Symbol	Parameter	Min	Typ	Max	Unit
f <sub>MAX</sub>	Maximum SCK Clock Frequency	—	—	45	MHz

**Notes:**

- All setup and hold time parameters on external SPI interface are design-specific and generated by the Lattice Design Software too. These parameters include the following:
  - t<sub>SUmaster</sub> Master Setup Time (master mode)
  - t<sub>HOLDmaster</sub> Master Hold Time (master mode)
  - t<sub>SUslave</sub> Slave Setup Time (slave mode)
  - t<sub>HOLDslave</sub> Slave Hold Time (slave mode)
  - t<sub>SCK2OUT</sub> SCK to Out Delay (slave mode)
- The SCLK duty cycle needs to be specified in the Lattice Design Software as a timing constraint in order to ensure proper timing check on SCLK HIGH and LOW (t<sub>HI</sub>, t<sub>LO</sub>) time.

#### 4.15. Internal Oscillators (HFOSC, LFOSC)

Table 4.11. Internal Oscillators (HFOSC, LFOSC)

Parameter		Parameter Description	Spec/Recommended			Unit
Symbol	Conditions		Min	Typ	Max	
$f_{CLKHF}$	Commercial Temp	HFOSC Clock Frequency ( $t_j = 0\text{ }^{\circ}\text{C} - 85\text{ }^{\circ}\text{C}$ )	-10%	48	10%	MHz
	Industrial Temp	HFOSC Clock Frequency ( $t_j = -40\text{ }^{\circ}\text{C} - 100\text{ }^{\circ}\text{C}$ )	-20%	48	20%	MHz
$f_{CLKLF}$	—	LFOSC CLKK Clock Frequency	-10%	10	10%	kHz
$DCH_{CLKHF}$	Commercial Temp	HFOSC Duty Cycle ( $t_j = 0\text{ }^{\circ}\text{C} - 85\text{ }^{\circ}\text{C}$ )	45	50	55	%
	Industrial Temp	HFOSC Duty Cycle ( $t_j = -40\text{ }^{\circ}\text{C} - 100\text{ }^{\circ}\text{C}$ )	40	50	60	%
$DCH_{CLKLF}$	—	LFOSC Duty Cycle (Clock High Period)	45	50	55	%
$T_{sync\_on}$	—	Oscillator Output Synchronizer Delay	—	—	5	Cycles
$T_{sync\_off}$	—	Oscillator Output Disable Delay	—	—	5	Cycles

**Note:**

1. Glitchless enabling and disabling OSC clock outputs.

#### 4.16. sysI/O Recommended Operating Conditions

Table 4.12. sysI/O Recommended Operating Conditions

Standard	$V_{CCIO}$ (V)		
	Min	Typ	Max
LVC MOS 3.3	3.14	3.3	3.46
LVC MOS 2.5	2.37	2.5	2.62
LVC MOS 1.8	1.71	1.8	1.89

#### 4.17. sysI/O Single-Ended DC Electrical Characteristics

Table 4.13. sysI/O Single-Ended DC Electrical Characteristics

Input/Output Standard	$V_{IL}$		$V_{IH}$		$V_{OL}$ Max (V)	$V_{OH}$ Min (V)	$I_{OL}$ (mA)	$I_{OH}$ Max (mA)
	Min (V)	Max (V)	Min (V)	Max (V)				
LVC MOS 3.3	-0.3	0.8	2.0	$V_{CCIO} + 0.2\text{ V}$	0.4	$V_{CCIO} - 0.4$	8	-8
					0.2	$V_{CCIO} - 0.2$	0.1	-0.1
LVC MOS 2.5	-0.3	0.7	1.7	$V_{CCIO} + 0.2\text{ V}$	0.4	$V_{CCIO} - 0.4$	6	-6
					0.2	$V_{CCIO} - 0.2$	0.1	-0.1
LVC MOS 1.8	-0.3	$0.35 V_{CCIO}$	$0.65 V_{CCIO}$	$V_{CCIO} + 0.2\text{ V}$	0.4	$V_{CCIO} - 0.4$	4	-4
					0.2	$V_{CCIO} - 0.2$	0.1	-0.1

#### 4.18. Differential Comparator Electrical Characteristics

Table 4.14. Differential Comparator Electrical Characteristics

Parameter Symbol	Parameter Description	Test Conditions	Min	Max	Unit
$V_{REF}$	Reference Voltage to compare, on $V_{INM}$	$V_{CCIO} = 2.5\text{ V}$	0.25	$V_{CCIO} - 0.25\text{ V}$	V
$V_{DIFFIN\_H}$	Differential Input HIGH ( $V_{INP} - V_{INM}$ )	$V_{CCIO} = 2.5\text{ V}$	250	—	mV
$V_{DIFFIN\_L}$	Differential Input LOW ( $V_{INP} - V_{INM}$ )	$V_{CCIO} = 2.5\text{ V}$	—	-250	mV
$I_{IN}$	Input Current, $V_{INP}$ and $V_{INM}$	$V_{CCIO} = 2.5\text{ V}$	-10	10	$\mu\text{A}$

## 4.19. Typical Building Block Function Performance

### 4.19.1. Pin-to-Pin Performance (LVCMOS25)

**Table 4.15. Pin-to-Pin Performance (LVCMOS25)**

Function	Timing	Unit
<b>Basic Functions</b>		
16-Bit Decoder	16.5	ns
4:1 Mux	18.0	ns
16:1 Mux	19.5	ns

**Notes:**

- The above timing numbers are generated using the Lattice Design Software tool. Exact performance may vary with device and tool version. The tool uses internal parameters that have been characterized but are not tested on every device.
- Using a  $V_{CC}$  of 1.14 V at Junction Temperature 85 °C.

### 4.19.2. Register-to-Register Performance

**Table 4.16. Register-to-Register Performance**

Function	Timing	Unit
<b>Basic Functions</b>		
16:1 Mux	110	MHz
16-Bit Adder	100	MHz
16-Bit Counter	100	MHz
64-Bit Counter	40	MHz
<b>Embedded Memory Functions</b>		
256 x 16 Pseudo-Dual Port RAM	150	MHz

**Notes:**

- The above timing numbers are generated using the Lattice Design Software tool. Exact performance may vary with device and tool version. The tool uses internal parameters that have been characterized but are not tested on every device.
- Under worst case operating conditions.

## 4.20. sysDSP Timing

Over recommended operating conditions.

**Table 4.17. sysDSP Timing**

Parameter	Description	Min	Max	Unit
$f_{MAX8x8SMULT}$	Max frequency signed MULT8x8 bypassing pipeline register	—	50	MHz
$f_{MAX16x16SMULT}$	Max frequency signed MULT16x16 bypassing pipeline register	—	50	MHz

## 4.21. SPRAM Timing

Over recommended operating conditions.

**Table 4.18. Single Port RAM Timing**

Parameter	Description	Min	Max	Unit
$f_{MAXSRAM}$	Max frequency SPRAM (4/8/16-bit Read and Write)	70	—	MHz

## 4.22. Derating Logic Timing

Logic timing data provided in the following sections of the data sheet using Lattice design tools are worst case numbers in the operating range. Actual delays can be much faster. Lattice design tools can provide logic timing numbers at a particular temperature and voltage.

## 4.23. Maximum sysI/O Buffer Performance

**Table 4.19. Maximum sysI/O Buffer Performance**

I/O Standard	Max Speed	Unit
<b>Inputs</b>		
LVC MOS33	250	MHz
LVC MOS25	250	MHz
LVC MOS18	250	MHz
<b>Outputs</b>		
LVC MOS33	250	MHz
LVC MOS25	250	MHz
LVC MOS18	155	MHz
LVC MOS12	70	MHz

**Note:**

1. Measured with a toggling pattern.

## 4.24. iCE40 UltraPlus Family Timing Adders

Over recommended commercial operating conditions.

**Table 4.20. iCE40 UltraPlus Family Timing Adders**

Buffer Type	Description	Timing (Typ)	Units
<b>Input Adjusters</b>			
LVC MOS33	LVC MOS, $V_{CCIO} = 3.3\text{ V}$	0.18	ns
LVC MOS25	LVC MOS, $V_{CCIO} = 2.5\text{ V}$	0	ns
LVC MOS18	LVC MOS, $V_{CCIO} = 1.8\text{ V}$	0.19	ns
<b>Output Adjusters</b>			
LVC MOS33	LVC MOS, $V_{CCIO} = 3.3\text{ V}$	-0.12	ns
LVC MOS25	LVC MOS, $V_{CCIO} = 2.5\text{ V}$	0	ns
LVC MOS18	LVC MOS, $V_{CCIO} = 1.8\text{ V}$	1.32	ns
LVC MOS12	LVC MOS, $V_{CCIO} = 1.2\text{ V}$	5.38	ns

**Notes:**

- Timing adders are relative to LVC MOS25 and characterized but not tested on every device.
- LVC MOS timing measured with the load specified in the Switching Test Conditions table (Table 4.26).
- Commercial timing numbers are shown.

## 4.25. iCE40 UltraPlus External Switching Characteristics

Over recommended commercial operating conditions.

**Table 4.21. iCE40 UltraPlus External Switching Characteristics**

Parameter	Description	Device	Min	Max	Unit
<b>Clocks</b>					
<b>Global Clock</b>					
$f_{MAX\_GBUF}$	Frequency for Global Buffer Clock Network	All Devices	—	185	MHz
$t_{W\_GBUF}$	Clock Pulse Width for Global Buffer	All Devices	2	—	ns
$t_{ISKEW\_GBUF}$	Global Buffer Clock Skew within a Device	All Devices	—	530	ps
<b>Pin-LUT-Pin Propagation Delay</b>					
$t_{PD}$	Best Case Propagation Delay through One LUT Logic	All Devices	—	9.0	ns
<b>General I/O Pin Parameters (Using Global Buffer Clock without PLL)<sup>1</sup></b>					
$t_{SKEW\_IO}$	Data Bus Skew across a Bank of IOs	All Devices	—	510	ps
$t_{CO}$	Clock to Output – PIO Output Register	All Devices	—	10.0	ns
$t_{SU}$	Clock to Data Setup – PIO Input Register	All Devices	-0.5	—	ns
$t_H$	Clock to Data Hold – PIO Input Register	All Devices	5.55	—	ns
<b>General I/O Pin Parameters (Using Global Buffer Clock with PLL)</b>					
$t_{COPLL}$	Clock to Output – PIO Output Register	All Devices	—	2.4	ns
$t_{SUPLL}$	Clock to Data Setup – PIO Input Register	All Devices	7.3	—	ns
$t_{HPLL}$	Clock to Data Hold – PIO Input Register	All Devices	-1.1	—	ns

**Note:**

1. All the data is from the worst cases.

## 4.26. sysCLOCK PLL Timing

Over recommended operating conditions.

**Table 4.22. sysCLOCK PLL Timing**

Parameter	Descriptions	Conditions	Min	Max	Unit
$f_{IN}$	Input Clock Frequency (REFERENCECLK, EXTFEEDBACK)	—	10	133	MHz
$f_{OUT}$	Output Clock Frequency (PLLOUT)	—	16	275	MHz
$f_{VCO}$	PLL VCO Frequency	—	533	1066	MHz
$f_{PFD}^3$	Phase Detector Input Frequency	—	10	133	MHz
<b>AC Characteristics</b>					
$t_{DT}$	Output Clock Duty Cycle	—	40	60	%
$t_{PH}$	Output Phase Accuracy	—	—	±12	deg
$t_{OPJIT}^{1, 5, 6}$	Output Clock Period Jitter	$f_{OUT} \geq 100$ MHz	—	450	ps p-p
		$f_{OUT} < 100$ MHz	—	0.05	UIPP
	Output Clock Cycle-to-Cycle Jitter	$f_{OUT} \geq 100$ MHz	—	750	ps p-p
		$f_{OUT} < 100$ MHz	—	0.10	UIPP
	Output Clock Phase Jitter	$f_{PFD} \geq 25$ MHz	—	275	ps p-p
		$f_{PFD} < 25$ MHz	—	0.05	UIPP
$t_W$	Output Clock Pulse Width	At 90% or 10%	1.33	—	ns
$t_{LOCK}^{2, 3}$	PLL Lock-in Time	—	—	50	µs
$t_{UNLOCK}$	PLL Unlock Time	—	—	50	ns
$t_{IPJIT}^4$	Input Clock Period Jitter	$f_{PFD} \geq 20$ MHz	—	1000	ps p-p
		$f_{PFD} < 20$ MHz	—	0.02	UIPP
$t_{STABLE}^3$	LATCHINPUTVALUE LOW to PLL Stable	—	—	500	ns
$t_{STABLE\_PW}^3$	LATCHINPUTVALUE Pulse Width	—	100	—	ns

Parameter	Descriptions	Conditions	Min	Max	Unit
$t_{RST}$	RESET Pulse Width	—	10	—	ns
$t_{RSTREC}$	RESET Recovery Time	—	10	—	$\mu$ s
$t_{DYNAMIC\_WD}$	DYNAMICDELAY Pulse Width	—	100	—	VCO Cycles

**Notes:**

1. Period jitter sample is taken over 10,000 samples of the primary PLL output with a clean reference clock. Cycle-to-cycle jitter is taken over 1000 cycles. Phase jitter is taken over 2000 cycles. All values are per JESD65B.
2. Output clock is valid after  $t_{LOCK}$  for PLL reset and dynamic delay adjustment.
3. At minimum  $f_{PFD}$ . As the  $f_{PFD}$  increases the time decreases to approximately 60% of the value listed.
4. Maximum limit to prevent PLL unlock from occurring. Does not imply the PLL operates within the output specifications listed in this table.
5. The jitter values increases with loading of the PLD fabric and in the presence of SSO noise.

## 4.27. SPI Master or NVCM Configuration Time

**Table 4.23. SPI Master or NVCM Configuration Time<sup>1, 2</sup>**

Symbol	Parameter	Conditions	Max	Unit
$t_{CONFIG}$	POR/CRESET_B to Device I/O Active	All devices – Low Frequency (Default)	140	ms
		All devices – Medium frequency	50	ms
		All devices – High frequency <sup>3</sup>	—	—

**Notes:**

1. Assumes sysMEM Block is initialized to an all zero pattern if they are used.
2. The NVCM download time is measured with a fast ramp rate starting from the maximum voltage of POR trip point.
3. High frequency is supported only on SPI Master.

## 4.28. sysCONFIG Port Timing Specifications

Over recommended operating conditions.

**Table 4.24. sysCONFIG Port Timing Specifications**

Symbol	Parameter	Conditions	Min	Typ	Max	Unit
<b>All Configuration Mode</b>						
$t_{CRESET\_B}$	Minimum CRESET_B LOW pulse width required to restart configuration, from falling edge to rising edge.	—	200	—	—	ns
$t_{DONE\_IO}$	Number of configuration clock cycles after CDONE goes HIGH before the PIO pins are activated.	—	49	—	—	Clock Cycles
<b>Slave SPI</b>						
$t_{CR\_SCK}$	Minimum time from a rising edge on CRESET_B until the first SPI WRITE operation, first SPI_SCK clock. During this time, the iCE40 UltraPlus device is clearing its internal configuration memory.	—	1200	—	—	$\mu$ s
$f_{MAX}$	CCLK Clock Frequency	Write	1	—	25	MHz
		Read <sup>1</sup>	—	15	—	MHz
$t_{CCLKH}$	CCLK Clock Pulsewidth HIGH	—	20	—	—	ns
$t_{CCLKL}$	CCLK Clock Pulsewidth LOW	—	20	—	—	ns
$t_{STSU}$	CCLK Setup Time	—	12	—	—	ns
$t_{STH}$	CCLK Hold Time	—	12	—	—	ns
$t_{STCO}$	CCLK Falling Edge to Valid Output	—	13	—	—	ns
<b>Master SPI<sup>3</sup></b>						

Symbol	Parameter	Conditions	Min	Typ	Max	Unit
$f_{MCLK}$	MCLK Clock Frequency	Low Frequency	7.0	12.0	17.0	MHz
		Medium Frequency <sup>2</sup>	21.0	33.0	45.0	MHz
		High Frequency <sup>2</sup>	33.0	53.0	71.0	MHz
$t_{MCLK}$	CRESET_B HIGH to First MCLK Edge	—	1200	—	—	$\mu$ s
$t_{SU}$	CCLK Setup Time	—	6.16	—	—	ns
$t_{HD}$	CCLK Hold Time	—	1	—	—	ns

**Notes:**

1. Supported with 1.2 V  $V_{CC}$  and at 25 °C.
2. Extended range  $f_{MAX}$  Write operations support up to 53 MHz with 1.2 V  $V_{CC}$  and at 25 °C.
3.  $t_{SU}$  and  $t_{HD}$  timing must be met for all MCLK frequency choices.

## 4.29. RGB LED Drive

**Table 4.25. RGB LED**

Symbol	Parameter	Min	Max	Unit
ILED_ACCURACY	RGB0, RGB1, RGB2 Sink Current Accuracy to selected current @ $V_{LEDOUT} \geq 0.5$ V	-12	+12	%
ILED_MATCH	RGB0, RGB1, RGB2 Sink Current Matching among the 3 outputs @ $V_{LEDOUT} \geq 0.5$	-5	+5	%

## 4.30. Switching Test Conditions

Figure 4.3 shows the output test load that is used for AC testing. The specific values for resistance, capacitance, voltage, and other test conditions are listed in Table 4.26.

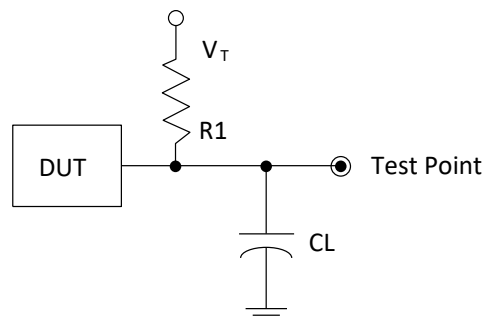
**Figure 4.3. Output Test Load, LVCMOS Standards**
**Table 4.26. Test Fixture Required Components, Non-Terminated Interfaces**

Test Condition	$R_1$	$C_L$	Timing Reference	$V_T$
LVCMOS settings ( $L \geq H$ , $H \geq L$ )	$\infty$	0 pF	LVCMOS 3.3 = 1.5 V	—
			LVCMOS 2.5 = $V_{CCIO}/2$	—
			LVCMOS 1.8 = $V_{CCIO}/2$	—
LVCMOS 3.3 ( $Z \geq H$ )	188	0 pF	1.5 V	$V_{OL}$
LVCMOS 3.3 ( $Z \geq L$ )			1.5 V	$V_{OH}$
Other LVCMOS ( $Z \geq H$ )			$V_{CCIO}/2$	$V_{OL}$
Other LVCMOS ( $Z \geq L$ )			$V_{CCIO}/2$	$V_{OH}$
LVCMOS ( $H \geq Z$ )			$V_{OH} - 0.15$ V	$V_{OL}$
LVCMOS ( $L \geq Z$ )			$V_{OL} - 0.15$ V	$V_{OH}$

**Note:**

1. Output test conditions for all other interfaces are determined by the respective standards.

## 5. Pinout Information

### 5.1. Signal Descriptions

#### 5.1.1. Power Supply Pins

Signal Name	Function	I/O	Description
V <sub>CC</sub>	Power	—	Core Power Supply
V <sub>CCIO_0</sub> , SPI_V <sub>CCIO1</sub> , V <sub>CCIO_2</sub>	Power	—	Power for I/Os in Bank 0, 1, and 2
V <sub>PP_2V5</sub>	Power	—	Power for NVCM programming and operations
V <sub>CCPLL</sub>	Power	—	Power for PLL
GND	GROUND	—	Ground
GND_LED	GROUND	—	Ground for LED drivers. Should connect to GND on board.

#### 5.1.2. Configuration Pins

Signal Name		Function	I/O	Description
General I/O	Shared Function			
CRESET_B	—	Configuration	I	Configuration Reset, active LOW. No internal pull-up resistor. Either actively driven externally or connect a 10 kΩ pull-up to SPI_V <sub>CCIO1</sub> .
IOB_xxx	CDONE	Configuration	I/O	Configuration Done. Includes a weak pull-up resistor to SPI_V <sub>CCIO1</sub> .
		General I/O	I/O	In user mode, after configuration, this pin can be programmed as general I/O in user function. In 30-pin WLCSPP, this pin connects to IOB_12a, which also is shared as global signal G4 in user mode.

#### 5.1.3. Configuration SPI Pins

Signal Name		Function	I/O	Description
General I/O	Shared Function			
IOB_34a	SPI_SCK	Configuration	I/O	This pin is shared with device configuration. During configuration: In Master SPI mode, this pin outputs the clock to external SPI memory. In Slave SPI mode, this pin inputs the clock from external processor.
		General I/O	I/O	In user mode, after configuration, this pin can be programmed as general I/O in user function.
IOB_32a	SPI_SO	Configuration	Output	This pin is shared with device configuration. During configuration: In Master SPI mode, this pin outputs the command data to the external SPI memory. In Slave SPI mode, this pin connects to the MISO pin of the external processor.
		General I/O	I/O	In user mode, after configuration, this pin can be programmed as general I/O in user function.
IOB_33b	SPI_SI	Configuration	Input	This pin is shared with device configuration. During configuration: In Master SPI mode, this pin receives data from external SPI memory. In Slave SPI mode, this pin connects to the MOSI pin of the

Signal Name		Function	I/O	Description
General I/O	Shared Function			
				external processor.
		General I/O	I/O	In user mode, after configuration, this pin can be programmed as general I/O in user function.
IOB_35b	SPI_SS	Configuration	I/O	This pin is shared with device configuration. During configuration: In Master SPI mode, this pin outputs to the external SPI memory. In Slave SPI mode, this pin inputs CSN from the external processor.
		General I/O	I/O	In user mode, after configuration, this pin can be programmed as general I/O in user function.

### 5.1.4. Global Pins

Signal Name		Function	I/O	Description
General I/O	Shared Function			
IOT_46b	G0	General I/O	I/O	In user mode, after configuration, this pin can be programmed as general I/O in user function.
		Global	Input	Global input used for high fanout, or clock/reset net. The G0 pin drives the GBUF0 global buffer.
IOT_45a	G1	General I/O	I/O	In user mode, after configuration, this pin can be programmed as general I/O in user function.
		Global	Input	Global input used for high fanout, or clock/reset net. The G1 pin drives the GBUF1 global buffer.
IOB_25b	G3	General I/O	I/O	In user mode, after configuration, this pin can be programmed as general I/O in user function.
		Global	Input	Global input used for high fanout, or clock/reset net. The G3 pin drives the GBUF3 global buffer.
IOB_12a	G4	General I/O	I/O	In user mode, after configuration, this pin can be programmed as general I/O in user function.
		Global	Input	Global input used for high fanout, or clock/reset net. The G4 pin drives the GBUF4 global buffer.
IOB_11b	G5	General I/O	I/O	In user mode, after configuration, this pin can be programmed as general I/O in user function.
		Global	Input	Global input used for high fanout, or clock/reset net. The G5 pin drives the GBUF5 global buffer.
IOB_3b	G6	General I/O	I/O	In user mode, after configuration, this pin can be programmed as general I/O in user function.
		Global	Input	Global input used for high fanout, or clock/reset net. The G6 pin drives the GBUF6 global buffer.

### 5.1.5. General I/O, LED Pins

Signal Name		Function	I/O	Description
General I/O	Shared Function			
RGB0	—	General I/O	Open-Drain I/O	In user mode, when RGB function is not used, this pin can be connected to any user logic and used as open-drain I/O. This pin is located in Bank 0.
		LED	Open-Drain Output	In user mode, when using RGB function, this pin can be programmed as an open-drain 24 mA output to drive the external LED.

Signal Name		Function	I/O	Description
General I/O	Shared Function			
RGB1	—	General I/O	Open-Drain I/O	In user mode, when RGB function is not used, this pin can be connected to any user logic and used as open-drain I/O. This pin is located in Bank 0.
		LED	Open-Drain Output	In user mode, when using RGB function, this pin can be programmed as an open-drain 24 mA output to drive the external LED.
RGB2	—	General I/O	Open-Drain I/O	In user mode, when RGB function is not used, this pin can be connected to any user logic and used as open-drain I/O. This pin is located in Bank 0.
		LED	Open-Drain Output	In user mode, when using RGB function, this pin can be programmed as an open-drain 24 mA output to drive the external LED.
PIOT_xx	—	General I/O	I/O	In user mode, with the user's choice, this pin can be programmed as I/O in user function in the top (xx = I/O location). These pins are located in Bank 0.
PIOB_xx	—	General I/O	I/O	In user mode, with the user's choice, this pin can be programmed as I/O in user function in the bottom (xx = I/O location). Pins with xx ≤ 9 are located in Bank 2, pins with xx > 9 are located in Bank 1.

## 5.2. Pin Information Summary

Pin Type		iCE40UP3K	iCE40UP5K	
		UWG30	UWG30	SG48
General Purpose I/O Per Bank	Bank 0	7	7	17
	Bank 1	10	10	14
	Bank 2	4	4	8
Total General Purpose I/Os		21	21	39
Differential Input/Output Pairs	Bank 0	2	2	6
	Bank 1	5	5	4
	Bank 2	1	1	3
Total Differential I/O Pair		8	8	13
V <sub>CC</sub>		1	1	2
V <sub>CCIO</sub>	Bank 0	1	1	1
	Bank 1	1	1	1
	Bank 2	1	1	1
V <sub>CCPLL</sub>		1	1	1
V <sub>PP_2V5</sub>		1	1	1
Dedicated Config Pins		1	1	2
GND		2	2	0*
Total Balls		30	30	48

**Note:**

1. 48-pin QFN package (SG48) requires the package paddle to be connected to GND.

### 5.3. iCE40UP Part Number Description

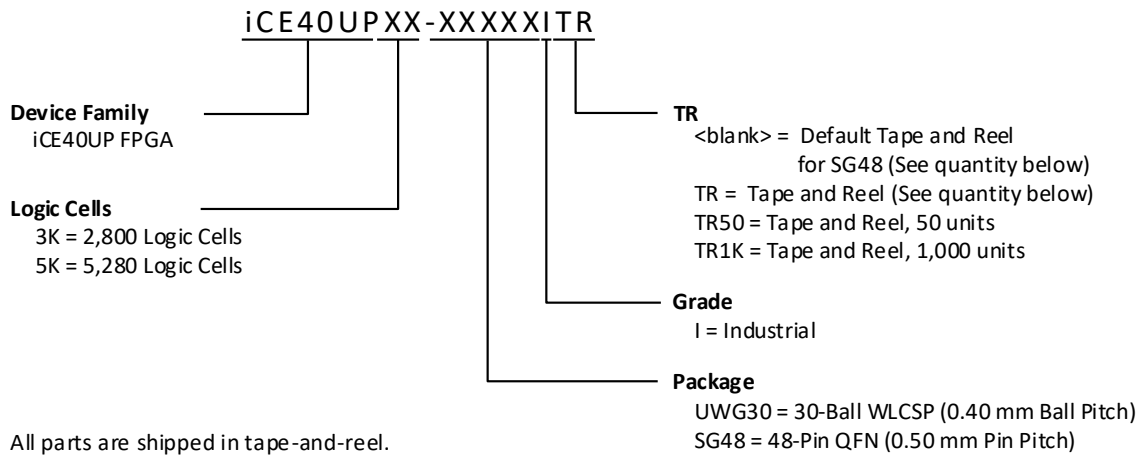

#### 5.3.1. Tape and Reel Quantity

Package	TR Quantity
UWG30	5,000
SG48	2,000

### 5.4. Ordering Part Numbers

#### 5.4.1. Industrial

Part Number	LUTs	Supply Voltage	Package	Pins	Temperature
iCE40UP3K-UWG30ITR	2800	1.2 V	Halogen-Free WLCSP	30	IND
iCE40UP3K-UWG30ITR1K	2800	1.2 V	Halogen-Free WLCSP	30	IND
iCE40UP3K-UWG30ITR50	2800	1.2 V	Halogen-Free WLCSP	30	IND
iCE40UP5K-SG48I	5280	1.2 V	Halogen-Free QFN	48	IND
iCE40UP5K-SG48ITR50	5280	1.2 V	Halogen-Free QFN	48	IND
iCE40UP5K-UWG30ITR	5280	1.2 V	Halogen-Free WLCSP	30	IND
iCE40UP5K-UWG30ITR1K	5280	1.2 V	Halogen-Free WLCSP	30	IND
iCE40UP5K-UWG30ITR50	5280	1.2 V	Halogen-Free WLCSP	30	IND

## Supplemental Information

### For Further Information

A variety of technical documents for the iCE40 UltraPlus family are available on the Lattice web site.

- [iCE40 Programming and Configuration \(FPGA-TN-02001\)](#)
- [iCE40 SPI/I2C Hardened IP Usage Guide \(FPGA-TN-02010\)](#)
- [Advanced iCE40 SPI/I2C Hardened IP Usage Guide \(FPGA-TN-02011\)](#)
- [Memory Usage Guide for iCE40 Devices \(FPGA-TN-02002\)](#)
- [iCE40 sysCLOCK PLL Design and Usage Guide \(FPGA-TN-02052\)](#)
- [iCE40 Hardware Checklist \(FPGA-TN-02006\)](#)
- [iCE40 LED Driver Usage Guide \(FPGA-TN-02021\)](#)
- [DSP Function Usage Guide for iCE40 Devices \(FPGA-TN-02007\)](#)
- [iCE40 Oscillator Usage Guide \(FPGA-TN-02008\)](#)
- [iCE40 SPRAM Usage Guide \(FPGA-TN-02022\)](#)
- [iCE40 UltraPlus Pinout Files](#)
- [iCE40 UltraPlus Pin Migration Files](#)
- [Thermal Management](#)
- [Package Diagrams](#)
- [Lattice design tools](#)

## Technical Support Assistance

For assistance, submit a technical support case at [www.latticesemi.com/techsupport](http://www.latticesemi.com/techsupport).

For frequently asked questions, refer to the Lattice Answer Database at [www.latticesemi.com/Support/AnswerDatabase](http://www.latticesemi.com/Support/AnswerDatabase).

## Revision History

### Revision 2.2, July 2023

Section	Change Summary
Architecture	In Differential Comparators of the <a href="#">sysI/O Buffer</a> section: <ul style="list-style-type: none"> <li>changed <i>See the Pin Information Summary section to locate the corresponding paired I/Os with differential comparators</i> to <i>Refer to the Pin Information Summary section for the number of paired I/Os available in each bank to implement differential comparators</i>;</li> <li>newly added <i>Refer to the device pinout file from the Lattice website for exact pin locations</i>.</li> </ul>
Pin Information Summary	Newly added the data of Differential Input/Output Pairs.

### Revision 2.1, April 2023

Section	Change Summary
DC and Switching Characteristics	In Power-up Supply Sequence section, added Note “To check the $V_{SUPPLY(MIN)}$ shown in Figure 4.1, please refer to the minimum recommended operation conditions in Recommended Operating Conditions section.”
Supplemental Information	Added links for iCE40 UltraPlus Pinout Files and iCE40 UltraPlus Pin Migration Files in Supplemental Information section.
Technical Support Assistance	Added FAQ website link in Technical Support Assistance section.

### Revision 2.0, August 2021

Section	Change Summary
DC and Switching Characteristics	Updated units in Table 4.5. DC Electrical Characteristics

### Revision 1.9, December 2020

Section	Change Summary
DC and Switching Characteristics	<ul style="list-style-type: none"> <li>Updated values in Table 4.17. sysDSP Timing.</li> <li>Updated footnotes in Table 4.23. SPI Master or NVCM Configuration Time1, 2.</li> </ul>
—	Minor style adjustments

### Revision 1.8, August 2020

Section	Change Summary
Architecture	<ul style="list-style-type: none"> <li>Removed paragraph regarding SCLK and SDI inputs from sysCLOCK Phase Locked Loops (PLLs) section.</li> <li>Updated linked reference.</li> <li>Modified Figure 3.3. PLL Diagram.</li> </ul>
Supplemental Information	Updated document ID of sysCLOCK PLL Design and Usage Guide in For Further Information section.

### Revision 1.7, February 2020

Section	Change Summary
Disclaimers	Added this section.

### Revision 1.6, November 2018

Section	Change Summary
General Description	Corrected product dimensions from 2.15 mm × 2.55 mm to 2.11 mm × 2.54 mm.
Product Family	

**Revision 1.5, August 2018**

Section	Change Summary
All	Removed Copyright page.
DC and Switching Characteristics	Updated sysCONFIG Port Timing Specifications section. Updated tCR_SCK parameter in Table 4.24.
Pinout Information	<ul style="list-style-type: none"> <li>Updated Configuration SPI Pins section.</li> <li>Updated secondary signal name from SPI_SS_B to SPI_SS.</li> </ul>
Supplemental Information	Updated iCE40 Programming and Configuration document number.

**Revision 1.4, August 2017**

Section	Change Summary
All	<ul style="list-style-type: none"> <li>Changed document number from DS1056 to FPGA-DS-02008.</li> <li>Removed Preliminary from document cover page and header.</li> </ul>

**Revision 1.3, August 2017**

Section	Change Summary
All	<ul style="list-style-type: none"> <li>Changed document status from Advance to Preliminary.</li> <li>Updated footer.</li> </ul>
Architecture	<ul style="list-style-type: none"> <li>Corrected link to iCE40 LED Driver Usage Guide (TN1288).</li> <li>Added link to iCE40 SPRAM Usage Guide (TN1314).</li> </ul>
DC and Switching Characteristics	<ul style="list-style-type: none"> <li>Updated Typ VCC=1.2 V values for IPP_2VSPEAK and ICOOPEAK in Table 4.6. Supply Current.</li> <li>Added Min value for fMAXSRAM to Table 4.18. Single Port RAM Timing.</li> <li>Added LVCMOS12 information to Table 4.19. Maximum sysI/O Buffer Performance and Table 4.20. iCE40 UltraPlus Family Timing Adders.</li> <li>Updated Table 4.21. iCE40 UltraPlus External Switching Characteristics. Revised Max values for tISKEW_GBUF, tSKEW_IO, tCO, tCOPLL, and Min values for tSUPLL, tHPLL.</li> <li>Added Max values to Table 4.23. SPI Master or NVCM Configuration Time.</li> </ul>
Pinout Information	<ul style="list-style-type: none"> <li>Updated TR description in the iCE40UP Part Number Description section.</li> <li>Updated part number information in the Ordering Part Numbers section.</li> </ul>
Supplemental Information	<ul style="list-style-type: none"> <li>Corrected link to iCE40 LED Driver Usage Guide (TN1288).</li> <li>Added link to iCE40 SPRAM Usage Guide (TN1314).</li> <li>Added link to Package Diagrams.</li> </ul>

**Revision 1.2, June 2016**

Section	Change Summary
All	Updated template.
Introduction	Added QFN package in features list.
Product Family	<ul style="list-style-type: none"> <li>Added packages to Table 2.1. iCE40 UltraPlus Family Selection Guide.</li> <li>Added information on RGB PWM IP in Overview.</li> </ul>
Architecture	<ul style="list-style-type: none"> <li>Performed minor editorial changes.</li> <li>Added information on 256 kb SPRAM blocks.</li> <li>Changed headings in Table 3.2. Global Buffer (GBUF) Connections to Programmable Logic Blocks.</li> <li>Corrected VCCPLL format in Figure 3.3. PLL Diagram.</li> <li>Updated note in Table 3.4. sysMEM Block Configurations.</li> <li>Added reference to iCE40 SPRAM Usage Guide (TN1314).</li> <li>Revised sysI/O Buffer Banks information.</li> <li>Corrected VCCIO format in Figure 3.9. I/O Bank and Programmable I/O Cell.</li> <li>Revised Typical I/O Behavior During Power-up information.</li> <li>Revised Supported Standards information.</li> </ul>

Section	Change Summary
	<ul style="list-style-type: none"> <li>Revised heading in Table 3.9. Supported Input Standards.</li> <li>Revised heading and removed LVCMOS12 in Table 3.10. Supported Output Standards.</li> <li>Revised HFOSC information in On-Chip Oscillator section.</li> <li>Removed "An RGB PWM IP is also offered in the family." in RGB High Current Drive I/O Pins section.</li> </ul>
DC and Switching Characteristics	<ul style="list-style-type: none"> <li>Added the following figures: <ul style="list-style-type: none"> <li>Figure 4.1. Power Up Sequence with SPE_VCCIO1 and VPP_2V5 Not Connected Together.</li> <li>Figure 4.2. Power Up Sequence with All Supplies Connected Together to 1.8 V.</li> </ul> </li> <li>Updated note in Table 4.5. DC Electrical Characteristics.</li> <li>Added note in Table 4.6. Supply Current.</li> <li>Revised User SPI Specifications 1, 2 section.</li> <li>Removed symbols.</li> <li>Added notes.</li> <li>Revised Table 4.11. Internal Oscillators (HFOSC, LFOSC).</li> <li>Removed note in Table 4.13. sysI/O Single-Ended DC Electrical Characteristics.</li> <li>Changed to Lattice Design Software tool in Table 4.15. Pin-to-Pin Performance (LVCMOS25).</li> <li>Changed to Lattice Design Software tool and revised note in Table 4.16. Register-to-Register Performance.</li> <li>Added sysDSP Timing section.</li> <li>Added SPRAM Timing section.</li> <li>Removed LVCMOS12 and added timing values in Table 4.19. Maximum I/O Buffer Performance.</li> <li>Removed LVCMOS12 and added timing values in Table 4.20. iCE40 UltraPlus Family Timing Adders.</li> <li>Revised max values in Table 4.23. SPI Master or NVCM Configuration Time.</li> <li>Removed TBD conditions in Table 4.24. sysCONFIG Port Timing Specifications. Revised tHD parameter.</li> <li>Revised Table 4.25. High Current RGB LED and IR LED Drive.</li> </ul>
Pinout Information	<ul style="list-style-type: none"> <li>General update to Signal Descriptions section.</li> <li>Updated the iCE40UP Part Number Description section. Added FGW49 package.</li> <li>Added OPNs.</li> </ul>
Supplemental Information	Added reference to FPGA-TN-02022, iCE40 SPRAM Usage Guide .

### Revision 1.1, September 2015

Section	Change Summary
Architecture	Updated Architecture section. Replaced iCE5UP with iCE40UP.
Pinout Information	Updated Pin Information section. <ul style="list-style-type: none"> <li>Replaced iCE5UP with iCE40UP.</li> <li>Replaced SWG30 with UWG30.</li> </ul>
Ordering Information	Updated iCE40UP Part Number Description section. <ul style="list-style-type: none"> <li>Replaced iCE5UP with iCE40UP.</li> <li>Replaced SWG30 with UWG30.</li> </ul> Updated Ordering Part Numbers section. Replaced the table of part
Further Information	Removed reference to Schematic Symbols.

**Revision 1.0, August 2015**

Section	Change Summary
All	Initial release.





[www.latticesemi.com](http://www.latticesemi.com)